

(19)



Europäisches Patentamt

European Patent Office

Office européen des brevets



(11)

EP 0 688 189 B1

(12)

**EUROPEAN PATENT SPECIFICATION**

(45) Date of publication and mention  
of the grant of the patent:  
13.09.2000 Bulletin 2000/37

(51) Int. Cl. 7: **A61B 19/00, A61F 13/02**

(21) Application number: 94910858.3

(86) International application number:  
PCT/US94/02409

(22) Date of filing: 07.03.1994

(87) International publication number:  
WO 94/20041 (15.09.1994 Gazette 1994/21)

**(54) WOUND TREATMENT EMPLOYING REDUCED PRESSURE**

WUNDBEHANDLUNG UNTER ANWENDUNG VON REDUZIERTEM DRUCK

TRAITEMENT DES BLESSURES PAR APPLICATION D'UNE PRESSION REDUITE

(84) Designated Contracting States:  
AT BE CH DE DK ES FR GB GR IE IT LI LU MC NL  
PT SE

• MORYKWAS, Michael, J.  
Pfafftown, NC 27040 (US)

(30) Priority: 09.03.1993 US 28677

(74) Representative:  
Newby, Martin John et al  
JY & GW Johnson,  
Kingsbourne House,  
229-231 High Holborn  
London WC1V 7DP (GB)

(43) Date of publication of application:  
27.12.1995 Bulletin 1995/52

(73) Proprietor:  
WAKE FOREST UNIVERSITY  
Winston-Salem, NC 27157-1023 (US)

(56) References cited:  
WO-A-92/19313                      WO-A-93/09727  
DE-A- 4 111 122                    US-A- 3 874 387  
US-A- 4 382 441                    US-A- 4 834 110

(72) Inventors:  
• ARGENTA, Louis, C.  
Winston-Salem, NC 27104 (US)

EP 0 688 189 B1

Note: Within nine months from the publication of the mention of the grant of the European patent, any person may give notice to the European Patent Office of opposition to the European patent granted. Notice of opposition shall be filed in a written reasoned statement. It shall not be deemed to have been filed until the opposition fee has been paid. (Art. 99(1) European Patent Convention).

## Description

Field of the Invention

5 [0001] The present invention relates to an appliance for administering a reduced pressure treatment to a wound.

Background of the Invention

10 [0002] The treatment of open wounds that are too large to spontaneously close has long been a troublesome area of medical practice. Closure of an open wound requires inward migration of surrounding epithelial and subcutaneous tissue. Some wounds, however, are sufficiently large or infected that they are unable to heal spontaneously. In such instances, a zone of stasis in which localized edema restricts the flow of blood to the epithelial and subcutaneous tissue forms near the surface of the wound. Without sufficient blood flow, the wound is unable to successfully fight bacterial infection and is accordingly unable to close spontaneously.

15 [0003] An initial stage of wound healing is characterized by the formation of granulation tissue which is a matrix of collagen, fibronectin, and hyaluronic acid carrying macrophages, fibroblasts, and neovasculature that forms the basis for subsequent epithelialization of the wound. Infection and poor vascularization hinder the formation of granulation tissue within wounded tissue, thereby inhibiting wound healing. It therefore becomes desirable to provide a technique for increasing blood circulation within wounded tissue to promote spontaneous healing and to reduce infection.

20 [0004] Poor blood circulation and infection at the wound may also hinder attachment of skin grafts or flaps upon wounded tissue. Skin grafts and flaps will not attach to tissue that is poorly vascularized, infected or necrotic. However, grafts and flaps can be used with much greater success on tissue that, although wounded, is able to form granulation tissue. Accordingly, a technique for promoting blood circulation at the wounded tissue would also promote successful attachment, or "take," of skin grafts or flaps to the wounded tissue as a consequence of increased blood circulation

25 within the grafts or flaps.  
 [0005] Another problem encountered during the treatment of wounds is the selection of an appropriate technique for wound closure during the healing process. Sutures are often used to apply force to adjacent viable tissue in order to induce the edges of a wound to migrate together and heal. However, sutures apply a closure force to only a very small percentage of the area surrounding a wound. When there is scarring, edema, or insufficient tissue, the tension produced by the sutures can become great causing excessive pressure to be exerted by the sutures upon the tissue adjacent to each suture. As a result, the adjacent tissue often becomes ischemic thereby rendering suturing of large wounds counterproductive. If the quantity or size of the sutures is increased to reduce the tension required of any single suture, the quantity of foreign material within the wound is concomitantly increased and the wound is more apt to become infected. Additionally, the size or type of a particular wound may prevent the use of sutures to promote wound closure.  
 30 It therefore becomes desirable to provide an apparatus and method for closing a large wound that distributes a closure force evenly about the periphery of the wound.

35 [0006] Wounds resulting from ischemia, or lack of blood flow, are also often difficult to heal since decreased blood flow to a wound may inhibit normal immune reaction to fight infection. Patients that are bedridden or otherwise non-ambulatory are susceptible to such ischemic wounds as decubitus ulcers or pressure sores. Decubitus ulcers form as a result of constant compression of the skin surface and underlying tissue thus restricting circulation. Since the patient is often unable to feel the wound or to move sufficiently to relieve the pressure, such wounds can become self-perpetuating. Although it is common to treat such wounds with flaps, the conditions that initially caused the wound may also work against successful flap attachment. Wheelchair-bound paraplegics, for example, must still remain seated after treatment of pelvic pressure sores. It therefore becomes desirable to provide a treatment procedure for ischemic  
 40 wounds that can be conducted in situ upon an immobile or partially mobile patient.

45 [0007] Other types of wounds in which ischemia leads to progressive deterioration include partial thickness burns. A partial thickness burn is a burn in which the cell death due to thermal trauma does not extend below the deepest epidermal structures such as hair follicles, sweat glands, or sebaceous glands. The progression of partial thickness burns to deeper burns is a major problem in burn therapy. The ability to control or diminish the depth of burns greatly enhances the prognosis for burn patients and decreases morbidity resulting from burns. Partial thickness burns are formed of a zone of coagulation, which encompasses tissue killed by thermal injury, and a zone of stasis. The zone of stasis is a layer of tissue immediately beneath the zone of coagulation. Cells within the zone of stasis are viable, but the blood flow is static because of collapse of vascular structures due to localized edema. Unless blood flow is re-established within the zone of stasis soon after injury, the tissue within the zone of stasis also dies. The death of tissue within  
 50 the zone of stasis is caused by lack of oxygen and nutrients, reperfusion injury (re-establishment of blood flow after prolonged ischemia), and decreased migration of white blood cells to the zone resulting in bacterial proliferation. Again, it becomes desirable to provide a technique for treating burn wounds by enhancing blood circulation to the wounded tissue to inhibit burn penetration.

[0008] WC-A-9309727 is part of the prior art according to Article 54(3) EPC and discloses an appliance for administering a pressure treatment to a wound. However it does not disclose an appliance having rigid support means associated with and separate from a sheet-like cover.

[0009] US-A-3874387 discloses a valved haemostatic pressure cap in the form of an appliance administering a reduced pressure treatment to a wound. However it does not disclose a sheet-like cover or rigid support means which are associated with and separate from the cover.

### Summary of the Invention

[0010] The present invention seeks to provide a wound treatment appliance for treating a wound by applying reduced pressure (i.e. pressure that is below ambient atmospheric pressure) to the wound in a controlled manner for a selected time period. The application of reduced pressure to a wound provides such benefits as faster healing, increased formation of granulation tissue, closure of chronic open wounds, reduction of bacterial density within wounds, inhibition of burn penetration, and enhancement of flap and graft attachment. Wounds that have exhibited positive response to treatment by the application of negative pressure include infected open wounds, decubitus ulcers, dehisced incisions, partial thickness burns, and various lesions to which flaps or grafts have been attached.

[0011] According to the present invention there is provided an appliance according to the ensuing claim 1 for administering a reduced pressure treatment to a wound. The sealing means may be in the form of an adhesive applied to the underside of the wound cover for sealing the wound cover around the periphery of the wound. The sealing means may also include a separate sealing member such as an adhesive strip or a sealing ring in the form of a tubular pad or inflatable cuff secured to the wound cover for positioning around the periphery of the wound. In selected embodiments, the reduced pressure within the sealed enclosure under the wound cover may serve to seal the wound cover in position at the wound site. The reduced pressure appliance also includes a suction port for supplying reduced pressure within the sealed volume enclosed beneath the wound cover. The suction port may be in the form of a nipple on the wound cover. Alternatively, the suction port may be in the form of a tube attached to the wound cover or provided as a feedthrough beneath the wound cover. The appliance may also include a porous wound screen for placement in the wound or in position overlying the wound in order to prevent overgrowth of wound tissue during treatment. The wound screen is sufficiently porous to permit gas flow to the wound. The porous wound screen may be in the form of a sponge or open-cell foam material for placement in the wound. The porous screen may also include a rigid or semi-rigid screen for overlying the wound.

[0012] A vacuum system is connected with the reduced pressure appliance in order to provide suction or reduced pressure to the appliance. For this purpose, the vacuum system includes a suction pump or suction device for connection with the suction port of the appliance for producing the reduced pressure over the wound site. The vacuum system may include a section of hose or tube, such as a vacuum hose, that interconnects the suction device with the suction port of the appliance to provide the reduced pressure at the wound site. A collection device in the form of a fluid trap may be provided intermediate the vacuum hose of the suction device and the suction port of the appliance to trap any exudate which may be aspirated from the wound by the negative pressure appliance. A stop mechanism may also be provided for the vacuum system to halt production of the reduced pressure at the wound site in the event that an excessive quantity of exudate has been collected. The apparatus may also include a control device for controlling the pump and for providing intermittent or cyclic production of reduced pressure.

[0013] In a particular embodiment of the invention, the wound cover for the reduced pressure appliance may be in the form of a gas impermeable covering sheet of flexible polymer material, such as polyethylene, having an adhesive backing that provides the seal for securing the sheet over the wound site to provide an gas-tight or fluid-tight sealed enclosure over the wound site. The vacuum system of the wound treatment apparatus may include a suction pump having a vacuum hose that is connected with a suction tube serving as a suction port for the appliance. The suction tube for the appliance runs beneath the cover sheet that is sealed in position over the wound site and into the fluid-tight enclosure provided under the cover sheet. An adhesive backing on the cover sheet is used to provide a fluid-tight seal around the feedthrough for the suction tube at the wound site. Within the enclosure, the suction tube is connected with a piece of open-cell foam for placement in the wound. The open-cell foam functions to more uniformly apply reduced pressure or suction over the wound site while holding the cover sheet substantially out of the wound during the application of reduced pressure at the enclosed wound site.

[0014] An appliance according to the invention may be used to treat tissue damage by applying a negative or reduced pressure to a wound over an area sufficient to promote the migration of epithelial and subcutaneous tissue toward the wound and for a time period sufficient to facilitate closure of the wound. This is useful for treating pressure sores.

[0015] An appliance according to the invention can also be used to treat a burn wound by applying a negative or reduced pressure to the burn over an area and for a time sufficient to inhibit progression in the depth of the burn. This usage is useful on a partial thickness burn soon after its infliction.

[0016] An appliance according to the invention can be used to treat tissue damage by applying a negative or reduced pressure to a wound for a time sufficient to reduce bacterial density in the wound. The appliance may be applied to a wound for a selected time period such as at least three days to reduce the bacterial density of an infected wound to the point at which surgical closure can be attempted.

5 [0017] An appliance according to the invention may be used to enhance the attachment of adjacent tissue to a wound by applying negative or reduced pressure to a joined complex of the adjacent living tissue and the wound at a sufficient magnitude of reduced pressure and for a sufficient time duration to promote the migration of epithelial and subcutaneous tissue toward the complex. This enhances attachment of adjacent tissue to tissues of the wound edges. Another use of the appliance is to enhance attachment of an open skin graft to the wound tissue.

10

#### Brief Description of the Drawings

[0018] The foregoing summary, as well as the following detailed description of the preferred embodiments of the present invention, will be better understood when read in conjunction with the appended drawings, in which:

15

FIG. 1 is a schematic elevational view of an exemplary appliance for administering a reduced pressure treatment to a wound, the appliance, shown in partial section, including a flexible, fluid impermeable wound cover sealed over the wound and a foam wound screen positioned in the wound, and in which a vacuum system provides reduced pressure within the wound cover of the appliance;

20

FIG. 2 is a schematic sectional elevational view of a second exemplary reduced pressure appliance having a rigid, fluid impermeable wound cover sealed over a wound and a rigid or semi-rigid screen overlying the wound;

FIG. 3 is a schematic sectional elevational view of a third reduced pressure appliance having a rigid, fluid impermeable wound cover sealed over a wound;

25

FIG. 4 is a schematic sectional elevational view of a reduced pressure appliance in accordance with the present invention having a semi-rigid, fluid impermeable cover enclosing a wound and a rigid or semi-rigid screen overlying the wound, with an overlying flexible fluid impermeable cover sheet sealing the enclosure over the wound;

FIG. 5 is a schematic elevational view of a reduced pressure appliance, shown in partial section, in accordance with another embodiment of the present invention having a flexible, fluid impermeable wound cover over an inner rigid porous support cup;

30

FIG. 6 is a schematic elevational view of a reduced pressure appliance, shown in partial section, having a rigid outer frame with support legs for supporting a flexible, fluid impermeable sealing cover over a wound;

FIG. 7 is a schematic elevational view in partial section of an alternative fluid collection device having a float valve for use in the vacuum system of FIG. 1;

FIG. 8 is a schematic view of an alternative vacuum system;

35

FIG. 9 is a schematic view of an alternative vacuum system incorporating a fluid collection device having an actuator for de-activating the vacuum system upon collection of a predetermined quantity of fluid;

FIG. 10 is a schematic cross-sectional view of a reduced or negative pressure appliance comprising an open-cell polymer foam screen, a flexible hose for connecting the foam screen with a vacuum system, and an adhesive-backed flexible polymer sheet overlying the foam-hose assembly to provide a seal over a wound; and

40

FIG. 11 is a schematic cross-sectional view of a reduced or negative pressure appliance comprising a rigid porous screen for a wound, a rigid or semi-rigid cup for covering the wound having an inflatable cuff attached about the base of the cup, and a flexible hose extending from the cup for connection with a vacuum system.

#### Detailed Description of the Preferred Embodiments

45

[0019] A wound treatment apparatus is provided for treating a wound by application of reduced pressure (i.e., below atmospheric pressure) so that suction may be applied to a wound site in a controlled manner for a selected time period. As schematically shown in Fig. 10, a wound treatment apparatus includes a reduced pressure appliance, generally designated 600, which is applied to a wound site to treat the wound through the application of reduced pressure. The appliance 600 is sealed in position over the wound site to create a generally fluid-tight or gas-tight enclosure over the wound site.

50

[0020] The appliance 600 includes a substantially flat section of open cell polyester foam section 610 (Fischer Scientific, Pittsburgh, PA 15219) sufficiently large to cover the wound and thus prevent wound overgrowth, a flexible hollow tube 611 (Fischer Scientific) inserted into the open cell foam section 610 and joined thereto with an adhesive and extending to attach at its opposite end with a Gast Vacuum pump (Fischer Scientific), and an loban adhesive sheet 612 (Minnesota Mining and Manufacturing, St. Paul, MN 55144) overlying the foam section 610 and tubing 611 and adhered to the skin surrounding the wound, thus forming a seal that allows creation of a vacuum when the suction pump operates. Such an appliance 600 would most preferably be packaged in a sterile condition to ameliorate the need for steri-

55

lization of the apparatus prior to use. The adhesive sheet 612 may be packaged separately from the foam-tube assembly 610 and 611. A particular advantage of this configuration is its use with pressure sores because the device can be placed in the depths of the wound and the patient can lie upon the device without either affecting the utility of the device or further damaging the wound. This becomes critical if the patient cannot be moved from this posture for medical or other reasons.

[0021] As shown in FIG. 11, a reduced pressure appliance, generally designated 615, is schematically depicted. The reduced pressure appliance 615 includes an adult CPR mask 620 (Doug Brown and Associates, Huntington Beach, CA 92648) comprising a rigid or semi-rigid fluid impermeable cup 621 having an inflatable cuff 622 mounted around the periphery of the base of the cup 622 for contact with the skin, an open cell polyester screen 624 overlying the wound, and a flexible 6.35 cm (1/4 inch) diameter hose 623 (Fischer Scientific) connected by a Nalgene tubing connector extending through a sealed hole in the cup for connection with a vacuum pump (Fischer Scientific). The hose 623 is connected with the pump 40 of a vacuum system 30 of the type shown in FIG. 1 to provide reduced pressure within the cup 621. The vacuum created within the cup 621 by the vacuum system may be sufficient to seal the cup in position over the wound site. Alternatively, fluid impermeable adhesive covering or strips may also be used to seal the appliance 615 in proper position.

[0022] Referring to FIG. 1, a wound treatment apparatus, generally designated 25, is depicted having a reduced pressure appliance 29 for enclosing a wound site to provide a fluid-tight or gas-tight enclosure over the wound site to effect treatment of a wound 24 with reduced or negative pressure. The wound treatment apparatus 25 includes a reduced pressure appliance, generally designated 29, which is applied to and sealed over a wound site in order to enclose the wound site for treatment with suction or reduced pressure within a sealed generally fluid-tight or gas-tight enclosure. For the purpose of creating suction within the appliance 29, the appliance 29 is connected with a vacuum system, generally designated 30, to provide a source of suction or reduced pressure for the sealed appliance 29 at the wound site. The appliance 29 includes a fluid-impermeable wound cover 18 in the form of a flexible, adhesive, fluid impermeable polymer sheet for covering and enclosing the wound 24 and the surrounding normal skin 22 at the wound site. The wound cover 18 includes an adhesive backing 20 which functions to seal the wound cover to the normal skin 22 around the periphery of wound 24 to provide a generally gas-tight or fluid-tight enclosure over the wound 24. The adhesive cover sheet 18 must have sufficient adhesion to form a fluid-tight or gas-tight seal 19 around the periphery of the wound and to hold the sheet 18 in sealed contact with the skin during the application of suction or reduced or negative pressure.

[0023] The appliance 29 also includes a porous wound screen 10 which is placed within the wound 24. The wound screen 10 is placed over substantially the expanse of the wound to prevent its overgrowth. The size and configuration of the wound screen 10 can be adjusted to fit the individual wound. It can be formed from a variety of porous materials. The material should be sufficiently porous to allow oxygen to reach the wound. The wound screen 10 may be in the form of an open-cell polymer foam, such as a polyurethane foam, which is sufficiently porous to allow gas flow to and/or from the wound 24. Foams may be used that vary in thickness and rigidity, although it may be desirable to use a spongy material for the patient's comfort if the patient must lie upon the appliance during treatment. The foam may also be perforated to enhance gas flow and to reduce the weight of the appliance. As shown in FIG. 1, the screen 10 is cut to an appropriate shape and size to fit within the wound 24. Alternatively, the screen may be sufficiently large to overlap the surrounding skin 22.

[0024] The appliance 29 also includes a suction port in the form of a hollow suction tube 12 that connects with the vacuum system 30 to provide suction within the sealed enclosure. The suction tubing 12 serves as a suction port for appliance 29. An end segment 12a of the tubing 12 is embedded within the foam screen 10 for providing suction or reduced pressure within the enclosure provided under the wound cover 18. Embedding the open end of segment 12a of tubing 12 within the interior of the foam screen 10 permits the foam screen 10 to function as a shield to help prevent the wound cover 18 from being inadvertently sucked into sealing engagement with the open end of the tube thereby plugging the tube 12 and restricting gas flow. The tube segment 12a embedded within the foam screen 10 preferably has at least one side port 14 for positioning within the interior of the foam screen 10 to promote substantially uniform application of reduced pressure throughout the enclosure. Positioning the side port 14 of tube segment 12a within the interior of the foam screen 10 permits the foam screen 10 to function as a shield for the side port to thereby prevent the wound cover 18 from being sucked into the side port 14 and thereby restricting gas flow. The open cells of the foam screen 10 facilitate gas flow throughout the enclosure. In addition, the foam screen 10 functions to prevent wound overgrowth and to hold the wound cover 18 generally out of contact with the wound 24 during the application of suction within the enclosure.

[0025] Tubing 12 and tube segment 12a are sufficiently flexible to permit movement of the tubing but are sufficiently rigid to resist constriction when reduced pressure is supplied to the appliance 29 or when the location of the wound is such that the patient must sit or lie upon the tubing 12 or upon the reduced pressure appliance 29. The screen-tube assembly comprising the foam screen 10 and the tube 12 may be fabricated by snaking the end of the tube segment 12a through an internal passageway in the foam screen 10 such as by pulling the end of the tube segment 12a through

the passageway using forceps. Alternatively, fabrication of the screen-tube assembly may be accomplished by suspending the end of the tube segment 12a into a suitable mold or form and then blowing foam into the mold or form to embed the tube end segment 12a within the blow-molded foam screen. The screen-tube assembly 12 and 10 is preferably prepared prior to use under sterile conditions and then stored in an aseptic package.

[0026] In order to use the reduced pressure appliance 29 at the site of the wound 24, the flexible, gas-impermeable, adhesive wound cover sheet 18 is secured in position at the wound site overlying the foam screen 10 disposed within the wound 24. The wound cover sheet 18 is secured and sealed to the surrounding normal skin 22 by an adhesive layer 20 on the under surface of the wound cover 18 to form a gas-tight seal 19 around the periphery of the wound 24. The wound cover 18 also provides a gas-tight seal around the tubing 12 at the feedthrough location 22a where the tubing 12 emerges from beneath the wound cover 18. The wound cover 18 is preferably formed of a fluid impermeable or gas impermeable flexible adhesive sheet such as Ioban, a product of the 3M corporation of Minneapolis, Minn.

[0027] The vacuum system 30 includes a suction pump 40 that produces a source of reduced pressure or suction which is supplied to the reduced pressure appliance 29 by suction tubing 12. As shown in FIG. 1, a fluid trap, generally designated 28, is interconnected between the suction pump 40 and the appliance 29 to remove and collect any exudate which may be aspirated from the wound 24 by the reduced pressure appliance. The appliance 29 functions to actively draw fluid or exudate from the wound 24. Collection of exudate in a fluid trap 28 intermediate the pump 40 and the appliance 29 is desirable to prevent clogging of the pump 40. A suitable fluid trap 28 may be assembled from an Erlenmeyer or side-arm flask 31 having a top opening and a side-arm opening. The fluid trap 28 includes a first port 32 at the top opening of the flask for sealed connection to suction tubing 12. The first port 32 enables suction to be applied to the reduced pressure appliance 29 through the tubing 12 and also enables exudate from the wound covered by reduced pressure appliance 29 to be drained into the flask 31. The flask 31 provides a collecting vessel 33 for the fluid trap for containing and temporarily storing the collected exudate. A suction port 34 is provided at the side-arm opening of the flask to enable the application of suction from vacuum pump 40. The suction port 34 of the fluid trap 28 is connected to the vacuum pump 40 by vacuum line 36. The fluid trap 28 is sealed generally gas-tight to enable the suction pump 40 to supply suction to the appliance 29 through the fluid trap 28. A filter 38 such as micropore filter is preferably attached to the exhaust of the pump 40 to prevent potentially pathogenic microbes or aerosols from being vented to atmosphere by the vacuum pump 40.

[0028] Predetermined amounts of suction or reduced pressure are produced by the vacuum pump 40. The vacuum pump 40 is preferably controlled by a control device 44 such as a switch or a timer which may be set to provide cyclic on/off operation of the vacuum pump 40 according to user-selected intervals. Alternatively, the vacuum pump 40 may be operated continuously without the use of a cyclical timer.

[0029] The vacuum system 30 preferably includes a shut-off mechanism for halting or inhibiting the supply of the reduced pressure to the appliance 29 in the event that the exudate aspirated from the wound 24 exceeds a predetermined quantity. Interrupting the application of suction to the appliance 29 is desirable to prevent exsanguination in the unlikely event a blood vessel ruptures under the wound cover 18 during treatment. If, for example, a blood vessel ruptures in the vicinity of the wound 24, a shut-off mechanism would be useful to prevent the vacuum system 30 from aspirating any significant quantity of blood from the patient. As a safety feature, various mechanical or electrical detection mechanisms may be employed to detect the level of exudate in the fluid trap 28.

[0030] As shown in FIG. 7, a fluid trap 28 employing a collection bottle or flask 35 is provided for connection intermediate the pump 40 and the appliance 29 for collecting exudate from the wound site. The flask 35 has a side-arm port 43 connected to suction tube 12 leading to the reduced pressure appliance 29 and a suction port 34 located at the top 44 of the flask 35 connected to the vacuum hose 36 leading to the vacuum pump 40. For the purpose of detecting liquid level within the flask 35, a float valve assembly, generally designated 39, is provided. The float-valve assembly 39 functions to close and seal off the suction port 34 of the fluid trap 28 when the quantity of exudate in the collecting vessel 33 exceeds a predetermined quantity. The float valve assembly 39 is provided in the form of a ball 46 which is held and suspended within a cage 47 positioned below a valve seat 48 disposed within the opening at the top 44 of the flask 35. The ball 46 has a specific gravity below that of the exudate so that the ball 46 will float upon the exudate and will be lifted against the valve seat 48 as the vessel 33 fills with exudate. When the ball 46 is firmly seated against the valve seat 48, the float valve 39 blocks suction port 34 and thereby shuts off the source of suction from vacuum line 36. The suction within the appliance 29 at the wound site arrests thus halting the aspiration of exudate from the wound.

[0031] Other types of mechanisms may be employed to detect the liquid level within the fluid trap 28 in order to arrest operation of the vacuum source. An alternative vacuum system 30a is shown in FIG. 8 in which a filter 38a is employed in vacuum line 36 for filtering the fluid or gas flow through the vacuum line 36 and for detecting the level of liquid in fluid trap 28. Exudate from the wound is collected in vessel 33. When the vessel 33 becomes full, aspiration of further exudate from the wound causes the vacuum line 36 to begin to collect exudate which eventually reaches the in-line filter 38a positioned in the vacuum line 36 intermediate the fluid trap 28 and the pump 40a having operational control 44a. The filter 38a contains a filter element that is selected to clog when exposed to sufficient amounts of moisture to thereby halt the supply of suction through the fluid trap 28 to the appliance 29. The filter 38a is preferably an in-line,

disc-shaped submicron filter having a nitrocellulose or PTFE filtration element for filtering particles larger than about .1  $\mu\text{m}$  from the vacuum line 36. In addition to preventing excess fluid aspiration, the filter 38a in the vacuum line 36 prevents contamination of the vacuum pump 40 by filtering potentially pathogenic microbes and aerosols.

[0032] Other types of detection devices may also be employed to detect a predetermined level of liquid collected in collection vessel 33. For example, collection of exudate in excess of a predetermined quantity may enable actuation of an electronic switch which turns off the vacuum pump or otherwise halts the supply of suction to the reduced pressure appliance 29. Referring to FIG. 9, the suction tubing 12 from the reduced pressure appliance 29 is connected to a three-port coupling device 160 that interconnects suction tube 12, vacuum line 36b and fluid collecting apparatus 131. The coupling device 160 permits transmission of suction from the vacuum line 36b of the pump 40b to the suction tubing 12. The coupling device 160 also permits aspirated exudate from tubing 12 to be collected in an expandable container, such as an intravenous fluid bag 162, housed beneath the coupling device 160 in a rigid housing vessel 33b. As exudate is collected, the bag 162 expands to conform to the shape of the interior surface of the surrounding rigid vessel 33b. An actuator 166, such as a spring-loaded actuator switch, is located within the side wall of the rigid vessel 33b and functions to shut off the pump 40b upon actuation of the switch 166. When the bag 162 expands sufficiently to contact and actuate switch 166 as shown in dashed lines at 162a in FIG. 9, the switch 166 is opened and the supply of power to the pump 40b along power line 164 is interrupted and the supply of suction to the appliance 29 is stopped. The actuator switch 166 may also cooperate with control 44b for the pump 40b to stop operation of the pump 40b. Other types of devices may also be employed to detect fluid levels in fluid trap 28. For example, weight detectors may be employed to detect a predetermined weight limit as the fluid trap fills with exudate or other liquid. Alternatively, optical sensors or detectors may also be employed.

[0033] For the purpose of protecting the site of a wound from impact or abrasion during treatment, a reduced pressure appliance employing a rigid or semi-rigid wound cover may be utilized over the site of the wound. As shown in FIG. 2, a reduced pressure appliance 29a includes a CPR mask 58 that provides a rigid wound cover for enclosing an appropriately-sized wound 74. The mask 59 is impermeable to fluids or gases so that a fluid-tight or gas-tight enclosure is effected over the wound site. The mask 59 is sufficiently rigid to support itself away from the wound during the application of suction or reduced pressure so that the mask 59 does not collapse into the wound 74. The CPR mask 58 is of the type having an inflatable air cuff 59 around the base of the mask. The cuff 59 may be inflated via an external valve for sealing the mask 59 against the normal skin 72 around the periphery of the wound 74. The air cuff 59 also prevents the base of the mask from digging into the skin 72 during application of reduced pressure. An optional screen 50 for preventing overgrowth of the wound 74 may be positioned to overlie the wound 74. The screen 50 may be formed of a rigid or semi-rigid perforated polymer surgical mesh such as Prolene mesh. Alternatively, a section of honeycombed polyethylene sheet may be cut to a suitable size and shape to overlie the wound 74. The screen 50 is held against the surrounding normal skin 72 in position overlying wound 74 by the cuff 59 which overlaps at least a portion of the periphery of the screen 50. The CPR mask 58 also includes a suction port in the form of a hose connector 54 to which one end of a suction tube 52 is attached. The other end of tube 52 is connected with a vacuum system 30 of the type previously described to provide a source of suction or reduced pressure for the appliance 29a. Suction produced within the appliance 29a may be sufficient to seal the cuff 59 to the skin and to thereby seal the appliance 29a in position over the wound site. However, in order to ensure a gas-tight seal between the reduced pressure appliance 29a and the surrounding skin 72, the mask 58 may also be secured to the treatment site with a fluid impermeable adhesive seal 68. The adhesive seal 68 may be formed of a flexible adhesive material such as an adhesive tape or an adhesive sheet that has been cut to surround and at least partially overlie the cuff 59. As shown in FIG. 2, the adhesive seal is secured to the base portion of the rigid mask 58 and to the normal skin 72 around the periphery of the air cuff 59 to seal the mask in position over the wound site.

[0034] As shown in FIG. 3, a reduced pressure appliance 29b is depicted having a rigid, fluid impermeable, cup-shaped wound cover 88 overlying a wound site. The appliance 29b is used to treat a wound 114 without any screen either in the wound or overlying the wound. The cover cup 88 can be formed of a polymer such as polystyrene, HDPE, or other suitably rigid material. The cup 88 must be sufficiently rigid to support itself out of contact with the wound 114 during the application of suction or negative pressure so that the cup 88 does not collapse into the wound. Reduced pressure is supplied to the interior of the cup 88 through the suction tubing 82 connected to suction port 84 in the form of a nipple sealed in position on the cup 88. The tubing 82 is also connected with a suitable vacuum system 30 of the type previously described to provide a source of suction or negative pressure within the appliance 29b. The base of the cup 88 supports an inflatable air cuff 89 to seal the cup 88 to the skin and to prevent the cup 88 from digging into the skin 92 and causing discomfort when reduced pressure is applied. The cuff 89 is positioned upon the normal skin 92 surrounding the wound 94. While the suction created within the cup 88 may be sufficient to hold the appliance in position by causing the air cuff to seal to the skin, more effective attachment of the appliance to the surrounding skin 92 may be obtained by the use of a strip of fluid impermeable, adhesive material secured to the skin 102 and to the base of the cup 88 over the air cuff 89 around the periphery of the base of the cup 88. The layer of adhesive material 98 helps to ensure that a fluid-tight or gas-tight seal is maintained between the cup 88 and the surrounding skin 92 so that a fluid-

tight enclosure is formed over the wound site.

[0035] Referring to FIG. 4, a reduced pressure appliance 29c in accordance with the present invention is depicted for enclosing a wound site for the treatment of wound 114 with suction or reduced pressure. The reduced pressure appliance 29c includes a fluid-impermeable wound covering, generally designated 116, having an outer flexible, adhesive polymer sheet 117 applied over an inner, generally circular, semi-rigid shield 118, such as a polystyrene shield, for covering and enclosing the wound site. The base of the shield 118 is positioned over a circular pad 109 which may be formed from flexible tubing to prevent the base of the cup from digging into the skin 102 and causing discomfort when suction is applied to the appliance 29c. The pad 109 may also facilitate sealing of the cover shield 118 in position over the wound site to form a fluid-tight or gas-tight enclosure over the wound site. The pad 109 may be positioned directly onto the normal skin 102 surrounding the wound 114 or, as shown in FIG. 4, the pad 109 may overlie an outer peripheral portion of a rigid screen 100 in order to hold the screen 100 in a position overlying the wound to prevent wound overgrowth. A suction port 104 is provided at the top of the shield 118 to permit gas-tight connection to suction tube 112. The suction port 104 may be in the form of a removable connector that is screwed into position at the top of the shield 118. Suction tube 112 functions to connect the appliance 29c to a suitable vacuum system 30 of the type previously described. For the purpose of enhancing the sealing of the appliance 29c in position over the wound site, an oversized, generally circular, adhesive, fluid impermeable polymer sheet 117 is adhered and secured to the top surface of the shield 118. The oversized adhesive sheet 117 extends beyond the outer periphery of the shield 118 so that the adhesive sheet 117 provides a sealing ring 119 of material around the periphery of the shield. The sealing ring 119 is sealed and adhered to the normal skin 102 around the outer periphery of pad 109. When sealed in position overlying wound 114, the appliance 29c provides a generally fluid-tight or gas-tight enclosure over the wound site.

[0036] Referring to FIG. 5, another reduced pressure appliance 29d in accordance with the present invention is depicted for enclosing and treating a wound 124 with suction or reduced pressure. A rigid or semirigid porous cup 138 is placed rim side down upon a porous screen or pad 120 located within a wound 124. The cup 138 has perforations 133 for equalizing pressure inside and outside of the cup 138. A flexible, fluid impermeable adhesive polymer cover sheet 128 is draped over the cup 138 to enclose the wound 124. The adhesive cover sheet 128 is adhered and sealed to the top portion of the cup 138 and to the surrounding normal skin 122 by adhesive layer 129 on the underside of the cover sheet 128 to provide a fluid-tight enclosure beneath the sheet 128. The cup 138 provides a generally central support beneath the cover sheet 128 to hold the cover sheet 128 out of contact with the wound 124 during application of suction. The cup 138 has a central suction port 134 sealed in position at the top of the cup 128 to permit connection by suction tube 132 to a vacuum system 30 of the type previously described. When reduced pressure is supplied to the appliance 29d, the cover sheet 128 is deformed downward and inward to position 128a as shown in phantom in FIG. 5. Tension developed within the deformed sheet 128a by virtue of the suction is exerted upon the surrounding skin by the sheet at position 128a. The outer periphery 124a of the wound 124 is pulled inward by virtue of such tension to the position shown in phantom at 124b to promote closure of the wound. The tension within the sheet at position 128a also exerts a downward force upon the cup 138 which more firmly presses the cup 138 onto the wound 124. Such downward force on the cup 138 may be desired in such applications as flap or graft attachment to promote contact between the flap or graft and the underlying tissue. The pad 124 under the cup 138 helps to alleviate discomfort caused by the downward force on the cup 138.

[0037] For applications where a downward pressure of the appliance into a wound is not desired, a reduced pressure appliance 29e, as shown in FIG. 6, may be utilized having a support structure, generally designated 151, which is positioned external to a flexible sealing sheet 148 for covering a wound 144. The flexible cover sheet 148 is in the form of a flexible, fluid impermeable, adhesive polymer sheet. The reduced pressure appliance 29e shown in FIG. 6 includes an external support frame 151 in the form of a series of spider-like legs 158 radiating outwardly from a central support hub 155. The legs 158 hold the central hub 159 directly over the wound 144. A connector 153 is removably mounted to the hub 155 to permit a suction tube 152 to be connected with the flexible cover sheet 148. The connector 153 may screw together and apart to permit the connector to be removably mounted relative to the hub 155. The flexible adhesive sheet 148 is adhered to the connector 153 at hub 155 and to the surrounding normal skin 142 so that the sheet is suspended over the wound 144 from the hub 155 in tentlike fashion. The flexible sheet is adhesively sealed to the connector 153 at the hub 155 and is also adhesively sealed to the skin 142 around the periphery of the wound 144 to form a fluid-tight or gas-tight enclosure over the wound site. The legs 158 of the frame 153 extend radially outward from the hub 153 and stand upon feet members 159 which may rest upon the outer periphery of the sheet 148 to help hold the cover sheet 148 in a position from being sucked together during the application of suction. Alternatively, the feet members 159 may extend beyond the cover sheet 148 and may rest upon the surrounding tissue beyond the periphery of the cover sheet 148. The connector 153 supported on the hub 155 provides a suction port 154 through which suction is supplied to the appliance 29e via suction tube 152. Tube 152 is connected to a vacuum system 30 of the type previously described for supplying reduced pressure within the cover sheet 148. When suction or reduced pressure is introduced via port 154, the sheet 148 deforms inwardly and downwardly to the position shown in phantom at 148a thus developing tension which is exerted upon the surrounding skin 142. The deformed sheet in position at 148a pulls the



edges of the wound 144 inwardly to the position indicated in phantom at 144b hence promoting closure of the wound 144.

[0038] Negative pressure appliances are useful for treating a variety of wounds. Treatment of a wound can be carried out by securing a negative pressure appliance to the treatment site as previously shown and described, and then maintaining a substantially continuous or cyclical reduced pressure within the appliance until the wound has reached a desired improved condition. A selected state of improved condition may include formation of granulation tissue sufficient for the attachment of a flap or graft, reduction of microbial infection in the wound, arrest or reversal of burn penetration, closure of the wound, integration of a flap or graft with the underlying wounded tissue, complete healing of the wound, or other stages of improvement or healing appropriate to a given type of wound or wound complex. It may be preferable to change the appliance periodically, such as at 48 hour intervals, during treatment, particularly when using appliances incorporating a screen on or in the wound. The method is preferably practiced using a negative or reduced pressure ranging from 1.01 to 100.31 kPa (0.01 to 0.99 atmospheres), and more preferably practiced using a negative or reduced pressure ranging between 50.66 to 81.06 kPa (0.5 to 0.8 atmospheres). The time period for use of the method on a wound may preferably be at least 12 hours, but can be, for example, extended for one or more days. There is no upper limit beyond which use of the method is no longer beneficial; the method increases the rate of closure up to the time the wound actually closes. Satisfactory treatment of various types of wounds has been obtained via the use of reduced pressures equivalent to about 6.77 to 23.70 kPa (2 to 7 in. Hg) below atmospheric pressure.

[0039] Supplying reduced pressure to the appliance in an intermittent or cyclic manner has also been demonstrated to be useful for treating wounds. Intermittent or cyclic supply of reduced pressure to an appliance may be achieved by manual or automatic control of the vacuum system. A cycle ratio, the ratio of "on" time to "off" time, in such an intermittent reduced pressure treatment may be as low as 1:10 or as high as 10:1. The preferred ratio is approximately 1:1 which is usually accomplished in alternating 5 minute intervals of reduced pressure supply and non-supply.

[0040] A suitable vacuum system includes any suction pump capable of providing at least 45.3 g (0.1 pounds) of suction to the wound, and preferably up to three pounds suction, and most preferably up to fourteen (14) pounds suction. The pump can be any ordinary suction pump suitable for medical purposes that is capable of providing the necessary suction. The dimension of the tubing interconnecting the pump and the reduced pressure appliance is controlled by the pump's ability to provide the suction level needed for operation. A 6.35 cm (1/4 inch) diameter tube may be suitable.

[0041] A method of treating damaged tissue comprises the steps of applying negative pressure to a wound for a selected time and at a selected magnitude sufficient to reduce bacterial density in the wound. Open wounds are almost always contaminated with harmful bacteria. Generally a bacterial density of  $10^5$  bacterial organisms per gram of tissue is regarded as infected. It is generally accepted that at this level of infection, grafted tissue will not adhere to a wound. These bacteria must be killed, either through the wound host's natural immune response or through some external method, before a wound will close. The application of negative pressure to a wound appears to reduce the bacterial density of the wound. It is believed that this effect is due to either the bacteria's incompatibility with a negative pressure environment or the increased blood flow to the wound area, as blood brings with it cells and enzymes to destroy the bacteria. The method can be used to reduce bacterial density in a wound by at least half. More preferably, it can be used to reduce bacterial density by at least 1,000 fold. Most preferably, the method can be used to reduce bacterial density by at least 1,000,000 fold.

[0042] A method of treating a burn comprises the steps of applying negative pressure to the burn over an area with predetermined reduced pressure and for a time sufficient to inhibit formation of a full thickness burn. A partial thickness burn, one which has a surface layer of dead tissue and an underlying zone of stasis, is often sufficiently infected so that it will transform within 24-48 hours into a full thickness burn, one in which all epidermal structures are destroyed. The application of negative pressure to the wound prevents the infection from becoming sufficiently severe to cause destruction of the underlying epidermal structures. The magnitude, pattern, and duration of pressure application can vary with the individual wound.

[0043] A method for enhancing the attachment of living tissue to a wound comprises the steps of first joining the living tissue to the wound to form a wound-tissue complex, then applying a negative or reduced pressure of selected magnitude to the wound-tissue complex over an area sufficient to promote migration of epithelia and subcutaneous tissue toward the complex, with the negative pressure being maintained for a selected time period sufficient to facilitate closure of the wound. Attachment of living tissue to a wound is a common procedure that can take many forms. For example, one common technique is the use of a "flap," a technique in which skin tissue from an area adjacent to the wound is detached on three sides but remains attached on the fourth, then is moved onto the wound. Another frequently used technique is an open skin graft in which skin is fully detached from another skin surface and grafted onto the wound. The application of negative pressure to the wound-graft complex reduces bacterial density in the complex and improves blood flow to the wound, thereby improving the attachment of the grafted tissue. Further features of the apparatus and methods for the use thereof shall be made apparent in the following examples.

## Example 1 - Treatment of Open Wounds

[0044] In order to demonstrate the use of a negative pressure appliance in the treatment of open wounds, an animal study was conducted using pigs as subjects. Pigs are frequently used as subjects in wound healing studies since they have essentially the same skin and subcutaneous tissue structure as humans.

[0045] Five 15 kg Chester pigs were obtained and acclimated for 1 week prior to use. The animals were sedated with an intramuscular injection of ketamine (25 mg/kg): xylazine (2.5 mg/kg): acepromazin (5 mg/kg). The backs and sides of the animals were shaved and scrubbed for surgery. One percent halothane was administered by endotracheal tube for maintenance of anesthesia. Two circular wounds were created on the midline of the animals. The wounds were 2.5 cm in diameter having a depth reaching, but not including, the deep fascia over the spine (approximately 1 cm). Wounds in pigs in this site do not contract during healing. Alginate impressions were made of each wound to determine the volumes of the wounds.

[0046] A reduced pressure appliance of the type discussed in connection with FIGS. 2 and 11 was positioned over each wound, and the cups were sealed to the skin with an loban sheet. A non-compressible silicone tube was attached to the anterior appliance of each pig and a reduced pressure of 16.9 kPa (5 in. Hg) below atmospheric pressure was supplied to the anterior appliances. No reduced pressure was applied to the posterior wounds. The animals were allowed to recover from anesthesia and given food and water *ad libitum*. The tubes were suspended from a pulley system over the top of each pen arranged to provide each animal with full, unrestricted access to its pen.

[0047] The animals were sedated 48 hours after surgery as described above, and then daily thereafter, so that alginate impressions could be made of each wound. This routine was continued until the wounded areas were filled with granulation tissue until coplanar with the surrounding tissue. The results of this experiment, including time to complete filling of the wound space by granulation tissue and the rate of granulation tissue formation, are presented in Table 1. The data in the third column of Table 1 shows the number of days needed for the treated and non-treated wounds to heal. In order to allow comparisons between the healing rate of variously-sized wounds, the data in the fourth column is expressed as a healing rate in terms of cc granulation tissue per day. As can be seen, the treated wounds exhibited higher rates of healing than did the non-treated wounds. The wounds treated with reduced pressure filled with granulation tissue at an average rate that was 52.3% greater than the rate of granulation of the control wounds. Animals numbered 1 and 2 experienced intermittent loss of reduced pressure throughout the experiment, yet the treated wounds of these animals also healed significantly faster than their control wounds.

TABLE 1

Animal	Wound	Initial Wound Volume (cm <sup>3</sup> )	Days to Full Granulation	Fill Rate (cm <sup>3</sup> /day)	% Rate Increase Due to Treatment
#1	control	4.9	13	0.38	26.3
	Treated	5.3	11	0.48	
#2	Control	7.2	8	0.90	28.9
	Treated	9.3	8	1.16	
#3	Control	4.0	12	0.33	75.8
	Treated	3.5	6	0.58	
#4	control	4.7	11	0.43	65.1
	Treated	5.0	7	0.71	
#5	Control	4.7	11	0.43	65.1
	Treated	5.1	7	0.71	
Average	---	---	---	---	52.3

## Example 2 - Reduction of Infection

[0048] During the course of the experiment described as Example 1 above, it was observed that the reduced pressure-treated wounds were much cleaner and bled more spontaneously than non-treated wounds. It was therefore undertaken to determine the relative rates of clearance of a known bacterial inoculum from treated and non-treated wounds.

[0049] Five 15 kg pigs were obtained and wounds created as set forth in Example 1. Two 2.5 cm diameter defects were created on the dorsum of each pig using a sterile technique, with a 7.5 cm interval retained between the edges of the defects. Hemostasis was obtained by electrocautery. Prior to placement of the reduced pressure appliances,  $10^8$  organisms of *Staphylococcus aureus* in 1 ml saline solution were injected into each wound. The reduced pressure appliances of the type shown in FIGS. 2 and 11 were then attached as in Example 1, and a reduced pressure of 16.9 kPa (5 in. Hg) below atmospheric pressure was applied to one of the wounds upon each animal. Reduced pressure was not applied to the other wound upon each animal. T-shirts were placed over the animals and no antibiotics were given during the course of the study. The animals were sedated as in Example 1 at 24 hour intervals, and a 3 mm diameter full thickness biopsy was taken from each wound site daily. The devices were then reattached and reduced pressure re-applied. This routine was continued for one week.

[0050] The biopsy samples were weighed and sterile saline (99X biopsy weight) added. The tissue samples were homogenized in a tissue grinder and serial dilutions were made in triplicate. 100 microliters of each dilution was plated on a blood agar plate and incubated overnight. The number of colonies were counted on each plate and thus the number of organisms per gram of tissue was calculated. The data was recorded as the common logarithm of the number of organisms/gram tissue and is shown in Table 2.

TABLE 2

Average Log <sub>10</sub> (organisms/gm)							
	Day 0	Day 1	Day 2	Day 3	Day 4	Day 5	Day 7
Control	8.44	8.04	8.17	7.13	7.13	8.82	7.08
Treated	7.69	7.36	7.37	6.79	6.43	3.98	4.32

[0051] As can be seen in Table 2, the common logarithm of the average number of organisms per gram of tissue present in the treated and non-treated wounds decreased slightly for all five animals over the first 4 days. In the treated wounds, the mean log of organisms/gm decreased dramatically between days 4 and 5. The mean log of organisms/gm within the non-treated wounds increased during the same period. Using the traditional baseline of  $10^5$  organisms/gm to define infection, the data of Table 2 shows that the average treated wound was disinfected after four days of treatment while the average non-treated wound was still infected after 7 days.

### Example 3 - Treatment of Burns

[0052] Use of reduced pressure appliances upon burns has been found to retard the progression of partial thickness burns into full thickness burns. A partial thickness burn is a burn in which the depth of cell death due to thermal trauma does not extend below the level of the deepest epidermal structures (i.e., the base of hair follicles, sweat glands, sebaceous glands, etc.). A burn that is initially a partial thickness burn will often deepen and progress into a full thickness burn due to insufficient blood circulation to the epidermal cells beneath the partial burn.

### Example 3A

[0053] The backs of five 15 kg pigs were shaved and scrubbed for surgery. A 3.8 cm (1.5 inch) diameter brass rod was heated to 190°C in an oil bath. The rod was pressed onto the pig's skin for 15 seconds following a well-known technique of relating depth of burn to time and temperature. Three burns were created over the spine of each pig, separated by 5 cm intervals. Suction apparatus cups of the configuration shown in FIGS. 2 and 11 were placed over two of the burns, with silver sulphadiazine (Silvadine - Trade Mark) cream, the standard antibiotic cream applied to human burns prior to excision of burned tissue, applied to the third. Cefaxolin (Kefzol) (500 mg) was administered intramuscularly (antibiotic). Suction of 0.91 to 2.72 kg vacuum (2-6 pounds vacuum) was applied to one of the cups. A small (2 mm) punch biopsy was taken of the wounded area and examined histologically for depth of burn.

[0054] Biopsies were analyzed by a dermatopathologist who was not told the nature of the study. It was concluded that the suctioned tissue specimens were healthier and healing more quickly than non-suctioned specimens.

### Example 3B

[0055] A set of 2 cm diameter standardized depth partial thickness burns were created by pressing a heated metal rod to each side of five anesthetized pigs to create 16 burns on each side of each pig. Reduced pressure appliances of the type shown in FIGS. 2 and 11 were secured over each of the burns on the left side of each animal and a continuous

pressure of 20.3 kPa (6 in. Hg) was supplied to the reduced pressure appliances. The animals were anesthetized daily, and elliptical full-thickness biopsies extending from non-injured tissue, through the center of each burn, and into non-injured tissue were harvested, fixed in formalin, processed for histological analysis and stained with Hematoxylin/eosin and Gomori's trichrome. The histologic slides were then given to a Dermatopathologist for blind determination of burn depth according to the Breslow Local Scale of maximum depth of cell death below the surface of the skin.

[0056] The Breslow Level (maximum total depth) for the burns treated by reduced pressure was 0.095 mm. The maximum depth of the burns which were not treated by reduced pressure was 0.885 mm. The use of reduced pressure appliances thus resulted in a 112% reduction in the maximum depth of burn progression.

#### 10 Example 3C - Treatment of Burn With Negative Pressure

[0057] Patient B. is admitted with second and third degree burns over the face and upper extremities, including both hands, as a result of a house fire. A large mitten-shaped reduced pressure appliance of the general type shown in FIGS. 1 and 10 is placed over the patient's right hand, with open cell foam inserts placed between the fingers to apply reduced pressure to the interdigit spaces. Three pounds of vacuum is applied cyclically in a pattern of five minutes on, 5 minutes off. The appliance is changed on a three times per week schedule. Treatment is continued until the necrotic tissue sloughs off or is excised, followed by split thickness skin graft placement.

#### 20 Example 4 - Treatment of Flaps

[0058] In order to determine the effect of reduced pressure application upon skin flap survival, five 15 kg Chester pigs were obtained and acclimated for 1 week as described previously. Two dorsally-based 3 cm by 12 cm flap outlines were drawn using indelible ink on each side of the pigs, leaving 6 cm between each flap. The flaps were assigned to one of four groups as follows:

- (1) Dual-treated flaps are flaps that were exposed to reduced pressure both prior to and following surgery;
- (2) Pre-treated flaps are flaps that were exposed to reduced pressure prior to surgery, but were not exposed to reduced pressure after surgery;
- (3) Post-treated flaps are flaps that were exposed to reduced pressure following surgery; and
- (4) Control flaps are flaps that were not exposed to reduced pressure either pre- or post-surgery.

[0059] The pre-treated flaps were initially treated by covering an area surrounding one of the flap outlines on the left side of each animal with a reduced pressure appliance of the type shown in FIGS. 1 and 10 having a large piece of open cell foam into which a tube was inserted. The foam was covered and sealed to the flap area with impermeable adherent sheeting. A reduced pressure of 3.2 kg (7 pounds) was then continuously applied to the area for 7 days.

[0060] On the day of surgery, each pig was sedated as previously described and anesthesia was maintained by 1% halothane. Two 3 cm by 12 cm dorsally based flaps were created on each side of the pig following the flap outlines. The flaps were created at a depth immediately below the *panniculus carnosus* (a subcutaneous muscle layer). The flaps were raised and then sutured back in place with single, interrupted sutures of 3-0 nylon. The reduced pressure appliances were then placed over the anterior flaps on each side of the animal. A reduced pressure of 2.3-3.2 kg (5-7 pounds) was continuously applied to the anterior flaps. Each suction tube ran from the appliances on the animals upward through a pulley suspended over the pens and down to a vacuum trap bottle to collect any liquid exudate. A hose was connected from each vacuum trap bottle to a vacuum pump to supply the reduced pressure to the appliances. The animals had free access to all areas of the pen.

[0061] The animals were anesthetized 72 hours after surgery and the appliances were removed. Photographs of each side of the animals were taken, and tracings of the flaps (and encompassing any discolored areas) were made on acetate to allow for planimetric calculation of percent survival. The appliances were then replaced and reduced pressure re-applied. This routine was continued at 48 hour intervals until no further necrosis or healing of the flaps was observed.

[0062] The distal portions of all flaps were discolored 72 hours post surgery, with the flaps exposed to reduced pressure being lighter in color. The distal ends of all flaps appeared to necrose and an eschar formed over the distal portion of each flap. Over time the eschar spontaneously desquamated, exposing the outline of the original flap. The eschar over the control and pre-treated flaps consistently desquamated sooner than the post-treated and the dual-treated flaps. The control flaps had contracted to a Y shape which was evident after the eschar had desquamated. The dual-treated flaps had contracted slightly and appeared as long, thin rectangles after dislodgement of the eschar. The pre-treated flaps and post-treated flaps were intermediate between the control and dual-treated flaps in regard to flap contraction.

[0063] Dual-treated flaps exhibited the greatest survival in terms of percent retention (72.2%) of the original flap

size. The post-treated flaps had the second greatest survival (67.4%). The pretreated flaps had the third most flap survival (64.8%). The control flaps had the least flap survival (51.2%). All treated flaps (dual-treated; pre-treated; and post-treated) exhibited significantly greater surface area survival than the control flaps. The dual-treated flaps had significantly greater surface area survival than either the pre-treated or post-treated flaps. The pre-treated flaps were not significantly different than post-treated flaps in regard to flap survival.

#### Example 5 - Treatment of Decubitus Ulcers

[0064] Application of reduced pressure was tested upon chronic decubitus ulcers and was found to be effective in the treatment thereof. Necrotic soft tissue was removed from the ulcers prior to placement upon the treatment site of a reduced pressure appliance of the type described in connection with FIGS. 1 and 10. Treatment of decubitus ulcers was tested using both continuous and cyclic application of reduced pressure. It was found that cyclic application of reduced pressure was both more effective and produced less discomfort for the patients than continuous application. Cyclic application of reduced pressure was conducted according to an application schedule of 5 minutes of suction followed by 5 minutes of non-suction. In 15 patients tested, successful treatment required from 2 to 13 weeks. Thirteen of the ulcers healed completely and every ulcer treated demonstrated progressive decrease in size during treatment. The following case histories demonstrate the manner in which various pressure sores were treated:

[0065] Case 1 - A 39 year-old male T4 paraplegic had suffered from multiple recurrent pressure sores over a period of 8 years. He had been treated for a trochanteric decubitus with a tensor fascia lata flap which had developed a recurrent ulcer in the center of the flap 4 months prior to presentation. The ulcer was debrided of necrotic tissue to re-involved periosteum resulting in a wound measuring 12 cm by 5 cm with a depth of 5 cm. During the course of 4 weeks of cyclic reduced pressure application, the wound progressively closed and spontaneously re-epithelialized. Reduced pressure of 16.9 kPa (5 in. Hg) below atmospheric pressure was applied cyclically with 5 minute intervals of applied pressure followed by 5 minute intervals with no applied pressure. The wound remained healed more than 5 months after treatment.

[0066] Case 2 - A 45 year old male paraplegic suffered from a recurrent right ischial fossa pressure sore and abscess prior to treatment. Debridement of the wound was carried out with partial ischial resection. A week later, a re-advancement of the V-Y biceps femoris flap and rotation gluteus flap was performed. Six days later, the wound dehiscid and the patient developed bilateral pneumonia requiring ventilatory support. The flap became progressively edematous and firm and resisted all efforts at mobilization. At this point, reduced pressure treatment providing continuous, non-cyclic suction or a vacuum at approximately five 16.9 kPa (5 in. Hg) below atmospheric pressure was initiated. A total of 2 liters of fluid was removed by the reduced pressure appliance during the first 72 hours of treatment. Intravenous fluids were administered to replace the fluid removed from the wound. The appliance was replaced and the wound was examined three times each week. Treatment was continued for a total of six weeks during which the flap became progressively less indurated, granulation tissue formation rapidly progressed, the edges of the wound came into approximation, and the wound was healed completely.

[0067] Case 3 - A 51 year-old T1 paraplegic had multiple previous pressure sores culminating in bilateral asynchronous hip disarticulations and bilateral total thigh flaps. Seven months prior to admission, he developed a 7 cm by 23 cm pressure sore over the remnants of both ischia. Bone was exposed and no tissue was available for wound closure. Dressing changes over a period of three months had failed to improve the wound. A reduced pressure appliance was then secured to the wound. During the first 3 weeks of treatment, reduced pressure of 16.9 kPa (5 in. Hg) below atmospheric pressure was continuously applied. For the following 9 weeks, reduced pressure was applied cyclically in 5 minute intervals. The appliance was replaced every three days during treatment. In the course of the treatment, the wound first granulated to cover the bone completely and then the wound re-epithelialized from the margins. After 12 weeks of the treatment, a 2 cm by 5 cm scrotal flap was used to cover the midline area of the wound. The wound has remained stable beyond 6 months after treatment.

#### Example 6 - Treatment of Dehiscid Incisions

[0068] A 50 year old debilitated white male who had undergone a colostomy through a midline laparotomy was re-admitted to the hospital for wound dehiscence and evisceration following an upper respiratory infection. He was taken immediately to the operating room and the abdominal wall was closed with Prolene mesh. Six weeks after placement of the Prolene mesh, the wound was still open and measured 28 cm by 23 cm. Only sparse granulation tissue had grown through the Prolene mesh during the six weeks. At this time a large reduced pressure appliance of the type shown in FIG. 5 was placed on an underlying porous aquaplast sheet (WFR/Aquaplast Corp., Wycoff, NJ 07481) over top of the Prolene mesh/wound surface and the space closed with a covering tent of loban. A continuous vacuum of 16.9 kPa (5 in. Hg) below atmospheric pressure was applied. The appliance was changed three times per week. After 8 days of treatment, granulation tissue had grown through and totally covered the Prolene mesh. Two days later, the

patient was taken to the operating room, where the surrounding tissue was undermined and used to close 75% of the wound. Split thickness skin grafts were used to cover the remainder of the wound, and were placed on the bed of granulation tissue. There was 80% take of the grafts, and the remaining areas healed spontaneously with wet to dry dressing changes. The wound has remained stable 16 months after surgery.

#### Example 7 - Treatment of Infected Wound

[0069] Infected wounds have been successfully treated via application of reduced pressure as described in the following cases:

Case 1 - A 39 year old white male sustained severe avulsive trauma to his left lower extremity in a motor vehicle accident 10 years prior to presentation. He presented with a ten year history of chronic osteomyelitis and a 3 cm diameter open ulcer with exposure of bone of his left lateral malleolus. He had previously undergone 7 local surgical procedures to attempt closure of the wound. An arteriogram demonstrated a one vessel foot with diffuse atherosclerosis and post traumatic changes. The extremity was debrided of necrotic soft tissue and all involved bone saucerized. The patient was placed on a five week course of antibiotics. The day after debridement, a reduced pressure device of the type shown in FIGS. 2 and 11 was applied over the wound and a reduced pressure of 16.9 kPa (5 in. Hg) below atmospheric pressure was applied. The device was changed on a three times per week schedule. After 14 days of treatment, the wound was smaller and filled with granulation tissue which completely covered the previously exposed bone. A split thickness skin graft was placed over the wound and healed primarily. The wound has been stable for 13 months with no recurrence of osteomyelitis or tissue breakdown.

Case 2 - A 51 year old white male T8 paraplegic was admitted to the hospital for an infected left trochanteric pressure sore which had been present for one year and measured 4 cm by 6 cm. The patient had previously undergone multiple procedures for treatment of this condition including a V-Y advancement flap 4 months prior to presentation. A scan revealed possible chronic osteomyelitis of the left femur. It was decided to treat the potential osteomyelitis with a five week course of IV antibiotics. The wound was debrided, then treated using a reduced pressure appliance of the type shown in FIGS. 1 and 10 for 6 weeks with cyclical reduced pressure [16.9 kPa (5 in. Hg) below atmospheric pressure; 5 minutes on/5 minutes off]. The wound rapidly granulated and decreased in size. After 6 weeks the wound had closed and the patient discharged. The patient was readmitted 1 month later with a draining sinus tract to the bone. The previously scanned head of the left femur was resected and the wound closed primarily over drains. The wound healed without further problems.

#### Example 8 - Chronic Open Wound Secondary to Stasis Ulcers

[0070] A 45 year old black female patient with a 10 year history of bilateral stasis ulcers of the pretibial area was presented with bilateral 10 cm by 15 cm infected ulcers with exposed fascia. Two previous attempts at skin grafting in the previous year had failed. The patient was treated using a reduced pressure appliance of the type shown in FIGS. 1 and 10 for 14 days with cyclical (5 minutes on/5 minutes off) reduced pressure of approximately 16.9 kPa (5 in. Hg) below atmospheric pressure. After 14 days treatment, quantitative bacterial counts of both ulcers were below 10<sup>2</sup> bacteria/grain tissue, and both ulcers appeared as healthy granulating beds. Split thickness skin grafts were then applied and exhibited 100% take. The patient is ambulating, and the wounds have remained healed for 2 months, which is the longest The wounds had been healed in The last 10 years.

#### Example 9 - Enhancement of Blood Flow

[0071] It is believed that The efficacy of reduced pressure appliances in such treatments as have been described is due at least in part to enhancement of blood circulation within the treated wounds. In order to determine the effect of pressure application upon blood flow, a laser doppler needle probe was inserted into tissue adjacent to a pressure sore. A baseline flow level was recorded for thirty minutes. Then, the relative blood flow level was measured while a reduced pressure corresponding to 16.9 kPa (5 in. Hg) below atmospheric pressure was continuously applied to the wound for 30 minutes using a reduced pressure appliance of the type shown in FIGS. 1 and 10. During continuous reduced pressure application, the relative blood flow level was only slightly higher than the baseline level.

[0072] Then the supply of reduced pressure to the appliance was cycled on and off at equal 5 minute intervals. During the "off" portions of the cycle, the relative blood flow level was twice as high as the baseline level. It is postulated that the increased blood flow during The off cycle is likely due to a "rebound" phenomenon. During the "on" cycle, blood is drawn toward the wounded tissue from both the venous and arterial branches of the vascular network in the vicinity of the wound. During the "off" cycle, this blood is transported toward the venous branch of the vascular network at a rate that is greater than would have been observed in the absence of the preceding "on" cycle.

[0073] The terms and expressions which have been employed are used as terms of description and not of limitation and there is no intention in the use of such terms and expressions of excluding any equivalents of the features shown and described, or portions thereof, but it is recognized that various modifications are possible within the scope of the claimed invention.

5  
Claims

1. An appliance (29c) for administering a reduced pressure treatment to a wound comprising:
  - 10 (a) an impermeable cover (117) for covering and enclosing the wound (114) and for maintaining reduced pressure at the site of the wound;
  - (b) a seal (119) operably connected with the cover (117) for sealing said cover to tissue surrounding the wound;
  - (c) rigid support means (118); and
  - 15 (d) reduced pressure supply means (112) operably connected with the cover for connection to a source of suction for supplying and maintaining said reduced pressure beneath the cover, characterised in that said cover (117) is sheet-like and in that said rigid support means (118) is associated with and separate from said cover (117) for holding the cover out of contact with the wound.
2. An appliance according to claim 1, characterised in that it further comprises a screen (100) for preventing over-  
20 growth of wound tissue, said screen (100) being positioned between said wound (114) and said cover (117).
3. An appliance according to claim 2, characterised in that said screen (100) comprises a porous sheet.
4. An appliance according to claim 1, characterised in that said reduced pressure is from about 6.77 kPa (2 inch Hg)  
25 below atmospheric pressure to about 23.70 kPa (7 inch Hg) below atmospheric pressure.
5. An appliance according to any of claims 1 to 4, characterised in that said seal (119) includes an adhesive material on the cover for securing said cover to the tissue surrounding the wound.
- 30 6. An appliance according to claim 1, characterised in that said cover comprises a flexible sheet (128).
7. An appliance according to claim 6, characterised in that the support means (138) connects with said sheet (128) for supporting said sheet outward from the wound.
- 35 8. An appliance according to claim 7, characterised in that said support means comprises a support member (138) located between said sheet and the wound.
9. An appliance according to claim 8, characterised in that said support member includes a porous cup member (138) having a connection port (134) for connecting with said reduced pressure supply means (132).
- 40 10. An appliance according to claim 8, characterised in that it further comprises a pad (120) between the wound (124) and said support member (138) for alleviating discomfort caused in the wound by said support member.
- 45 11. An appliance according to claim 7, characterised in that said support means comprises a support member (151) extending outwardly over the wound (144) and external to said sheet (148).
- 50 12. An appliance according to claim 11, characterised in that said support means comprises attachment means for attaching said sheet to said support means, said attachment means having a connecting member (153) for connecting with said reduced pressure supply means for providing said reduced pressure beneath said sheet, and said support member (151) comprising a plurality of leg members (158) attached to said attachment means for holding said attachment means and said sheet outward from the wound.
- 55 13. An appliance according to claim 2, characterised in that said screen is adapted for placement at a location between the wound and said cover to prevent overgrowth of the wound and is secured in said location at the periphery of said cover.
14. An appliance according to claim 2, characterised in that said screen comprises a sheet-like mesh.

15. An appliance according to claim 12, characterised in that said seal includes an adhesive material on the cover for adhering to tissue surrounding the wound and a seal member at least partially overlying said cover.
16. An appliance according to any of the preceding claims, characterised in that said reduced pressure supply means comprises a vacuum system for producing a reduced pressure.
17. An appliance according to claim 16, characterised in that said vacuum system includes a collection device for collecting fluid aspirated from the wound.
18. An appliance according to claim 17, characterised in that said collection device includes means for halting said application of reduced pressure to the wound when said fluid exceeds a predetermined quantity.
19. An appliance according to any of claims 16 to 18, characterised in that said reduced pressure is from about 6.77 kPa (2 inch Hg) below atmospheric pressure to about 23.70 kPa (7 inch Hg) below atmospheric pressure.
20. An appliance according to any of claims 16 to 19, characterised in that said reduced pressure supply means comprises a length of tubing connected between said vacuum system and said cover and in that said vacuum system comprises:
- (a) a vacuum pump connected with said tubing; and
  - (b) a filter for preventing said pump from venting micro-organisms aspirated from the wound.
21. An appliance according to claim 20, characterised in that said filter is connected along said tubing between said pump and said cover for preventing contamination of said pump.
22. An appliance according to any of claims 16 to 21, characterised in that said vacuum system comprises control means for cyclically controlling said production of reduced pressure in alternating periods of production and non-production of reduced pressure.
23. An appliance according to claim 16, characterised in that said reduced pressure supply means comprises a length of tubing and said vacuum system comprises an aspirating container connected along said length of tubing between said vacuum system and cover and a flotation valve within said aspirating container for blocking said tubing when a predetermined amount of fluid is collected within said container.
24. An appliance according to claim 16, characterised in that said vacuum system comprises an expandable chamber and sensing means for sensing expansion of said expandable chamber, said sensing means being operatively connected with said vacuum system so that application of a reduced pressure to the wound is halted when a predetermined expansion of said expandable chamber is sensed by said sensing means.
25. An appliance according to claim 18, characterised in that said reduced pressure supply means comprises a length of tubing and said halting means comprises a filter along said tubing, said filter having pores that block the supply of reduced pressure via said tubing when said pores are filled with said fluid.
26. An appliance according to claim 1, characterised in that said reduced pressure supply means comprises an open cell foam screen for applying the reduced pressure to the wound, and a tube member embedded in said screen for extending from beneath the cover and for supplying the reduced pressure to said foam.
27. An appliance according to claim 26, characterised in that said tube member has a side port within the foam for promoting substantially uniform application of reduced pressure to the wound.
28. An appliance according to claim 26 or 27, characterised in that said foam screen is adapted to be conformed to the shape and size of the wound.
29. An appliance according to claim 1, characterised in that:
- (a) said cover comprises a deformable cover for placement over the wound;
  - (b) said seal comprises an adhesive layer on the cover for forming a seal between said cover and tissue surrounding the wound;



(c) said support means supports said cover outward from the wound forming an enclosed volume bounded by said cover and the wound and tissue surrounding the wound; and

(d) said reduced pressure supply means supplies reduced pressure to said enclosed volume and deforms said cover so as to maintain the reduced pressure on the wound and to exert tension upon the tissue surrounding the wound.

- 5
30. An appliance according to claim 29, characterised in that said support means comprises a support member positioned within said enclosed volume.
- 10
31. An appliance according to claim 30, characterised in that said support member comprises a porous cup member.
32. An appliance according to claim 30, characterised in that said support means comprises a support member positioned external to said enclosed volume.
- 15
33. An appliance according to claim 32, characterised in that said support means comprises attachment means for attaching said cover to said support means, and said support means comprises a plurality of leg members for supporting said cover out of contact with the wound.
- 20
34. An appliance according to any of claims 1 and 16, characterised in that only a single port is associated with said cover for connecting said reduced pressure supply means to said cover.
35. An appliance according to claim 8, characterised in that the support means includes a convex shield and the flexible sheet overlies and extends beyond the shield at the periphery of the sheet.
- 25
36. An appliance according to claim 35, characterised in that the seal cooperates with a portion of the flexible sheet that extends beyond the shield to seal the cover.
37. An appliance according to claim 35, characterised in that it further comprises a pad positioned between edges of the shield and the tissue surrounding the wound.
- 30

#### Patentansprüche

1. Vorrichtung (29c) zum Vornehmen einer Unterdruckbehandlung an einer Wunde, umfassend:
- 35
- (a) eine undurchlässige Abdeckung (117) zum Abdecken und Verschließen der Wunde (114) und zum Aufrechterhalten von Unterdruck an der Wundstelle;
- (b) eine Abdichtung (119) in Wirkverbindung mit der Abdeckung (117) zum Abdichten besagter Abdeckung gegenüber dem die Wunde umgebenden Gewebe;
- 40
- (c) ein starres Trägermittel (118); und
- (d) ein Mittel (112) zum Zuführen von Unterdruck in Wirkverbindung mit der Abdeckung zum Anschluss an ein Saugquelle zum Zuführen und Aufrechterhalten des Unterdrucks unter der Abdeckung, dadurch gekennzeichnet, dass die Abdeckung (117) flächenförmig ist und das starre Trägermittel (118) der Abdeckung (117) zugeordnet und davon getrennt ist, um eine Berührung der Wunde durch die Abdeckung zu vermeiden.
- 45
2. Vorrichtung nach Anspruch 1, dadurch gekennzeichnet, dass sie ferner eine Abschirmung (100) zum Verhindern einer Überwucherung von Wundgewebe umfasst, wobei diese Abschirmung (100) zwischen der Wunde (114) und der Abdeckung (117) angeordnet ist.
- 50
3. Vorrichtung nach Anspruch 2, dadurch gekennzeichnet, dass die Abschirmung (100) eine poröse Folie aufweist.
4. Vorrichtung nach Anspruch 1, dadurch gekennzeichnet, dass der Unterdruck im Bereich von ca. 6,77 kPa (2 Zoll Hg) unter Atmosphärendruck bis ca. 23,70 kPa (7 Zoll Hg) unter Atmosphärendruck liegt.
- 55
5. Vorrichtung nach einem der Ansprüche 1 bis 4, dadurch gekennzeichnet, dass die Abdichtung (119) ein Klebmaterial auf der Abdeckung zum Befestigen der Abdeckung auf dem die Wunde umgebenden Gewebe enthält.
6. Vorrichtung nach Anspruch 1, dadurch gekennzeichnet, dass die Abdeckung eine flexible Folie (128) enthält.

7. Vorrichtung nach Anspruch 6, dadurch gekennzeichnet, dass das Trägermittel (138) zur Unterstützung der Folie außerhalb der Wunde mit der Folie (128) verbunden ist.
8. Vorrichtung nach Anspruch 7, dadurch gekennzeichnet, dass das Trägermittel ein Trägerglied (138) umfasst, das zwischen der Folie und der Wunde angeordnet ist.
9. Vorrichtung nach Anspruch 8, dadurch gekennzeichnet, dass das Trägerglied ein poröses Becherglied (138) mit einer Anschlussöffnung (134) zur Verbindung mit dem Mittel (132) zum Zuführen von Unterdruck aufweist.
10. Vorrichtung nach Anspruch 8, dadurch gekennzeichnet, dass sie ferner ein Polster (120) zwischen der Wunde (124) und dem Trägerglied (138) zum Lindern von in der Wunde durch das Trägerglied verursachten Beschwerden enthält.
11. Vorrichtung nach Anspruch 7, dadurch gekennzeichnet, dass das Trägermittel ein Trägerglied (151) aufweist, das sich nach außen über die Wunde (144) und auf der Außenseite der Folie (148) erstreckt.
12. Vorrichtung nach Anspruch 11, dadurch gekennzeichnet, dass das Trägermittel ein Befestigungsmittel zum Befestigen der Folie an dem Trägermittel enthält, wobei das Befestigungsmittel ein Verbindungsglied (153) zum Verbinden mit dem Mittel zum Zuführen von Unterdruck, um unter der Folie den Unterdruck zu liefern, aufweist, und wobei das Trägerglied (151) mehrere beinförmige Glieder (158) umfasst, die an dem Befestigungsmittel befestigt sind, um das Befestigungsmittel und die Folie von der Wunde weg zu halten.
13. Vorrichtung nach Anspruch 2, dadurch gekennzeichnet, dass die Abschirmung zur Platzierung an einem Ort zwischen der Wunde und der Abdeckung vorgesehen ist, um eine Überwucherung der Wunde zu vermeiden, und an dieser Stelle am Umfang der Abdeckung befestigt ist.
14. Vorrichtung nach Anspruch 2, dadurch gekennzeichnet, dass die Abschirmung ein flächenförmiges Maschengeflecht umfasst.
15. Vorrichtung nach Anspruch 12, dadurch gekennzeichnet, dass die Abdichtung ein Klebematerial auf der Abdeckung zum Ankleben an die Wunde umgebendem Gewebe und ein zumindest teilweise über der Abdeckung liegendes Dichtungsglied umfasst.
16. Vorrichtung nach einem der vorhergehenden Ansprüche, dadurch gekennzeichnet, dass das Mittel zum Zuführen von Unterdruck ein Vakuumsystem zum Erzeugen eines Unterdrucks umfasst.
17. Vorrichtung nach Anspruch 16, dadurch gekennzeichnet, dass das Vakuumsystem eine Auffangvorrichtung zum Auffangen von aus der Wunde abgesaugter Flüssigkeit enthält.
18. Vorrichtung nach Anspruch 17, dadurch gekennzeichnet, dass die Auffangvorrichtung ein Mittel enthält zum Stoppen der Aufbringung von Unterdruck auf die Wunde, wenn die Flüssigkeit eine vorbestimmte Menge überschreitet.
19. Vorrichtung nach einem der Ansprüche 16 bis 18, dadurch gekennzeichnet, dass der Unterdruck im Bereich von ca. 6,77 kPa (2 Zoll Hg) unter Atmosphärendruck bis ca. 23,70 kPa (7 Zoll Hg) unter Atmosphärendruck liegt.
20. Vorrichtung nach einem der Ansprüche 16 bis 19, dadurch gekennzeichnet, dass das Mittel zum Zuführen von Unterdruck ein zwischen dem Vakuumsystem und der Abdeckung angeschlossenes Schlauchstück enthält und dass das Vakuumsystem folgendes umfasst:
  - (a) eine mit dem Schlauch verbundene Vakuumpumpe; und
  - (b) einen Filter zum Verhindern des Abführens von aus der Wunde angesaugten Mikroorganismen durch die Pumpe.
21. Vorrichtung nach Anspruch 20, dadurch gekennzeichnet, dass der Filter entlang dem Schlauch zwischen der Pumpe und der Abdeckung zum Verhindern einer Kontamination der Pumpe angeschlossen ist.
22. Vorrichtung nach einem der Ansprüche 16 bis 21, dadurch gekennzeichnet, dass das Vakuumsystem ein Steuermittel zur zyklischen Steuerung der Erzeugung von Unterdruck in alternierenden Phasen, in denen Unterdruck

erzeugt oder nicht erzeugt wird, umfasst.

23. Vorrichtung nach Anspruch 16, dadurch gekennzeichnet, dass das Mittel zum Zuführen von Unterdruck ein Schlauchstück umfasst und das Vakuumsystem einen entlang dem Schlauchstück zwischen dem Vakuumsystem und der Abdeckung angeschlossenen Aspirationsbehälter sowie ein Schwimmerventil in dem Aspirationsbehälter zum Blockieren des Schlauchs, wenn sich im Behälter eine vorbestimmte Flüssigkeitsmenge angesammelt hat, umfasst.
24. Vorrichtung nach Anspruch 16, dadurch gekennzeichnet, dass das Vakuumsystem eine expandierbare Kammer und Erfassungsmittel zum Erfassen einer Expansion der expandierbaren Kammer enthält, wobei die Erfassungsmittel mit dem Vakuumsystem in Wirkverbindung stehen, so dass die Aufbringung eines Unterdrucks auf die Wunde gestoppt wird, wenn durch das Erfassungsmittel eine vorbestimmte Expansion der expandierbaren Kammer festgestellt wird.
25. Vorrichtung nach Anspruch 18, dadurch gekennzeichnet, dass das Mittel zum Zuführen von Unterdruck ein Schlauchstück umfasst und das Stoppmittel einen Filter entlang dem Schlauchstück umfasst, wobei der Filter Poren aufweist, die die Zufuhr von Unterdruck über den Schlauch blockieren, wenn die Poren mit der Flüssigkeit gefüllt sind.
26. Vorrichtung nach Anspruch 1, dadurch gekennzeichnet, dass das Mittel zum Zuführen von Unterdruck eine Abschirmung aus offenzelligem Schaumstoff zum Aufbringen des Unterdrucks auf die Wunde und ein in die Abschirmung eingebettetes Schlauchglied, das sich von unterhalb der Abdeckung erstreckt und den Unterdruck dem Schaumstoff zuführt, enthält.
27. Vorrichtung nach Anspruch 26, dadurch gekennzeichnet, dass das Schlauchglied eine seitliche Öffnung im Schaumstoff enthält, um eine im wesentlichen gleichförmige Aufbringung von Unterdruck auf die Wunde zu fördern.
28. Vorrichtung nach Anspruch 26 oder 27, dadurch gekennzeichnet, dass die Schaumstoff-Abschirmung ausgelegt ist, an die Form und Größe der Wunde angepaßt zu werden.
29. Vorrichtung nach Anspruch 1, dadurch gekennzeichnet, dass:
- (a) die Abdeckung eine verformbare Abdeckung zur Platzierung über der Wunde enthält;
  - (b) die Abdichtung eine Klebschicht auf der Abdeckung zur Bildung einer Abdichtung zwischen der Abdeckung und dem die Wunde umgebenden Gewebe aufweist;
  - (c) das Trägermittel die Abdeckung außerhalb der Wunde trägt, wobei ein abgeschlossenes, von der Abdeckung und der Wunde und dem die Wunde umgebenden Gewebe begrenztes Volumen gebildet wird;
  - und (d) das Mittel zum Zuführen von Unterdruck dem abgeschlossenen Volumen Unterdruck zuführt und die Abdeckung so verformt, dass der Unterdruck auf der Wunde aufrechterhalten wird und auf das die Wunde umgebende Gewebe Spannung ausgeübt wird.
30. Vorrichtung nach Anspruch 29, dadurch gekennzeichnet, dass das Trägermittel ein innerhalb des abgeschlossenen Volumens angeordnetes Trägerglied umfasst.
31. Vorrichtung nach Anspruch 30, dadurch gekennzeichnet, dass das Trägerglied ein poröses Becherglied enthält.
32. Vorrichtung nach Anspruch 30, dadurch gekennzeichnet, dass das Trägermittel ein außerhalb des abgeschlossenen Volumens angeordnetes Becherglied umfasst.
33. Vorrichtung nach Anspruch 32, dadurch gekennzeichnet, dass das Trägermittel ein Befestigungsmittel zum Befestigen der Abdeckung an dem Trägermittel aufweist und das Trägermittel mehrere bein förmige Glieder zum Tragen der Abdeckung ohne Kontakt mit der Wunde umfasst.
34. Vorrichtung nach Anspruch 1 oder 16, dadurch gekennzeichnet, dass der Abdeckung nur eine einzige Öffnung zum Verbinden des Mittels zum Zuführen von Unterdruck mit der Abdeckung zugeordnet ist.
35. Vorrichtung nach Anspruch 8, dadurch gekennzeichnet, dass das Trägermittel ein konvexes Schutzschild aufweist

und die flexible Folie über dem Schutzschild liegt und sich über das Schutzschild an der Folienperipherie hinaus erstreckt.

36. Vorrichtung nach Anspruch 35, dadurch gekennzeichnet, dass die Abdichtung mit einem Teil der flexiblen Folie, die sich über das Schutzschild hinaus erstreckt, zusammenwirkt, um die Abdeckung abzudichten.
37. Vorrichtung nach Anspruch 35, dadurch gekennzeichnet, dass sie ferner ein zwischen Rändern des Schutzschildes und dem die Wunde umgebenden Gewebe positioniertes Polster umfasst.

#### Revendications

1. Appareil (29c) pour appliquer un traitement à pression réduite à une blessure, comprenant :
  - (a) une couverture imperméable (117) pour couvrir et enfermer la blessure (114) et pour maintenir une pression réduite à l'endroit de la blessure;
  - (b) un joint (119) relié de façon fonctionnelle à la couverture (117) pour sceller ladite couverture au tissu entourant la blessure;
  - (c) un moyen de support rigide (118), et
  - (d) un moyen pour fournir une pression réduite (112) relié de façon fonctionnelle à la couverture pour une liaison à une source de succion pour fournir et maintenir ladite pression réduite sous la couverture, caractérisé en ce que ladite couverture (117) est en forme de feuille et en ce que ledit moyen de support rigide (118) est associé à ladite couverture (117) et séparé de celle-ci pour garder la couverture hors de contact avec la blessure.
2. Appareil suivant la revendication 1, caractérisé en ce qu'il comprend en outre un écran (100) pour empêcher une croissance exagérée du tissu de la blessure, ledit écran (100) étant positionné entre ladite blessure (114) et ladite couverture (117).
3. Appareil suivant la revendication 2, caractérisé en ce que ledit écran (100) comprend une feuille poreuse.
4. Appareil suivant la revendication 1, caractérisé en ce que ladite pression réduite est d'environ 6,77 kPa (2 pouces de Hg) sous la pression atmosphérique à environ 23,70 kPa (7 pouces de Hg) sous la pression atmosphérique.
5. Appareil suivant l'une quelconque des revendications 1 à 4, caractérisé en ce que ledit joint (119) comprend un matériau adhésif sur la couverture pour fixer ladite couverture au tissu entourant la blessure.
6. Appareil suivant la revendication 1, caractérisé en ce que ladite couverture comprend une feuille flexible (128).
7. Appareil suivant la revendication 6, caractérisé en ce que le moyen de support (138) est en liaison avec ladite feuille (128) pour soutenir ladite feuille à l'extérieur de la blessure.
8. Appareil suivant la revendication 7, caractérisé en ce que ledit moyen de support comprend un élément de support (138) situé entre ladite feuille et la blessure.
9. Appareil suivant la revendication 8, caractérisé en ce que ledit élément de support comprend un élément formant cloche poreuse (138) ayant un orifice de liaison (134) pour se relier audit moyen de fourniture de pression réduite (132).
10. Appareil suivant la revendication 8, caractérisé en ce qu'il comprend en outre un coussinet (120) entre la blessure (124) et ledit élément de support (138) pour soulager l'inconfort causé à la blessure par ledit élément de support.
11. Appareil suivant la revendication 7, caractérisé en ce que ledit moyen de support comprend un élément de support (151) s'étendant vers l'extérieur au-dessus de la blessure (144) et en dehors de ladite feuille (148).
12. Appareil suivant la revendication 11, caractérisé en ce que ledit moyen de support comprend des moyens de fixation pour fixer ladite feuille audit moyen de support, ledit moyen de fixation ayant un élément de liaison (153) pour se relier audit moyen de fourniture de pression réduite pour fournir ladite pression réduite sous ladite feuille, et ledit élément de support (151) comprenant une pluralité d'éléments formant pieds (158) fixés audit moyen de fixation

pour garder ledit moyen de fixation et ladite feuille hors de la blessure.

- 5 13. Appareil suivant la revendication 2, caractérisé en ce que ledit écran est propre à être placé à un endroit entre la blessure et ladite couverture pour empêcher une croissance exagérée du tissu de la blessure et est fixé audit endroit à la périphérie de ladite couverture.
14. Appareil suivant la revendication 2, caractérisé en ce que ledit écran comprend un filet en forme de feuille.
- 10 15. Appareil suivant la revendication 12, caractérisé en ce que ledit joint comprend un matériau adhésif sur la couverture pour adhérer au tissu entourant la blessure et un élément de joint superposé au moins partiellement à ladite couverture.
16. Appareil suivant l'une quelconque des revendications précédentes, caractérisé en ce que ledit moyen pour fournir une pression réduite comprend un système de vide pour produire une pression réduite.
- 15 17. Appareil suivant la revendication 16, caractérisé en ce que ledit système de vide comprend un dispositif de récupération pour recueillir le fluide aspiré de la blessure.
18. Appareil suivant la revendication 17, caractérisé en ce que ledit dispositif de récupération comprend un moyen pour arrêter ladite application de pression réduite à la blessure quand ledit fluide dépasse une quantité prédéterminée.
- 20 19. Appareil suivant l'une quelconque des revendications 16 à 18, caractérisé en ce que ladite pression réduite est d'environ 6,77 kPa (2 pouces de Hg) sous la pression atmosphérique à environ 23,70 kPa (7 pouces de Hg) sous la pression atmosphérique.
- 25 20. Appareil suivant l'une quelconque des revendications 16 à 19, caractérisé en ce que ledit moyen d'application de pression réduite comprend une longueur de tube reliant ledit système de vide à ladite couverture, et en ce que ledit système de vide comprend :
- 30 (a) une pompe à vide reliée audit tube, et  
(b) un filtre pour empêcher ladite pompe de dégager des micro-organismes aspirés de la blessure.
21. Appareil suivant la revendication 20, caractérisé en ce que ledit filtre est relié le long du tube entre ladite pompe et ladite couverture pour empêcher une contamination de ladite pompe.
- 35 22. Appareil suivant l'une quelconque des revendications 16 à 21, caractérisé en ce que ledit système de vide comprend un moyen de contrôle pour contrôler de manière cyclique ladite production de pression réduite en périodes alternantes de production et de non-production de pression réduite.
- 40 23. Appareil suivant la revendication 16, caractérisé en ce que ledit moyen de fourniture de pression réduite comprend une longueur de tube et ledit système de vide comprend un récipient aspirateur relié le long de ladite longueur de tube entre ledit système de vide et ladite couverture et un clapet à flotteur à l'intérieur dudit récipient d'aspiration pour bloquer ledit tube quand une quantité prédéterminée de fluide est recueillie dans ledit récipient.
- 45 24. Appareil suivant la revendication 16, caractérisé en ce que ledit système de vide comprend une chambre extensible et un moyen capteur pour capter l'extension de ladite chambre extensible, ledit moyen capteur étant relié de façon fonctionnelle audit système de vide, de sorte que l'application d'une pression réduite à la blessure est arrêtée quand une extension prédéterminée de ladite chambre extensible est captée par ledit moyen capteur.
- 50 25. Appareil suivant la revendication 18, caractérisé en ce que ledit moyen de fourniture de pression réduite comprend une longueur de tube et ledit moyen d'arrêt comprend un filtre le long dudit tube, ledit filtre ayant des pores qui bloquent la fourniture de pression réduite par l'intermédiaire dudit tube quand lesdits pores sont remplis avec ledit fluide.
- 55 26. Appareil suivant la revendication 1, caractérisé en ce que ledit moyen de fourniture de pression réduite comprend un écran de mousse à alvéoles ouvertes pour appliquer la pression réduite à la blessure, et un élément de tube incorporé dans ledit écran pour s'étendre d'en dessous de la couverture et pour fournir la pression réduite à ladite mousse.

27. Appareil suivant la revendication 26, caractérisé en ce que ledit élément de tube présente un orifice latéral à l'intérieur de la mousse pour permettre une application essentiellement uniforme de la pression réduite à la blessure.
28. Appareil suivant la revendication 26 ou 27, caractérisé en ce que ledit écran de mousse est adapté pour se conformer à la forme et à la taille de la blessure.
29. Appareil suivant la revendication 1, caractérisé en ce que :
  - (a) ladite couverture comprend une couverture déformable à placer sur la blessure;
  - (b) ledit joint comprend une couche adhésive sur la couverture pour former un joint entre ladite couverture et ledit tissu entourant la blessure;
  - (c) ledit moyen de support soutient ladite couverture à l'extérieur de la blessure, formant un volume enfermé délimité par ladite couverture et la blessure et le tissu entourant la blessure, et
  - (d) ledit moyen de fourniture de pression réduite fournit une pression réduite audit volume enfermé, et déforme ladite couverture, de manière à maintenir la pression réduite sur la blessure et à exercer une tension sur le tissu entourant la blessure.
30. Appareil suivant la revendication 29, caractérisé en ce que ledit moyen de support comprend un élément de support situé à l'intérieur dudit volume enfermé.
31. Appareil suivant la revendication 30, caractérisé en ce que ledit élément de support comprend un élément formant cloche poreuse.
32. Appareil suivant la revendication 30, caractérisé en ce que ledit moyen de support comprend un élément de support positionné à l'extérieur dudit volume enfermé.
33. Appareil suivant la revendication 32, caractérisé en ce que ledit moyen de support comprend un moyen de fixation pour fixer ladite couverture audit moyen de support, et ledit moyen de support comprend une pluralité d'éléments formant pieds pour soutenir ladite couverture hors de contact avec la blessure.
34. Appareil suivant l'une quelconque des revendications 1 et 16, caractérisé en ce qu'un seul orifice est associé à ladite couverture pour relier ledit moyen de fourniture de pression réduite à ladite couverture.
35. Appareil suivant la revendication 8, caractérisé en ce que le moyen de support comprend un bouclier convexe et la feuille flexible recouvre et s'étend au-delà du bouclier à la périphérie de la feuille.
36. Appareil suivant la revendication 35, caractérisé en ce que le joint coopère avec une partie de la feuille flexible qui s'étend au-delà du bouclier pour sceller la couverture.
37. Appareil suivant la revendication 35, caractérisé en ce qu'il comprend en outre un coussinet positionné entre les bords du bouclier et le tissu entourant la blessure.

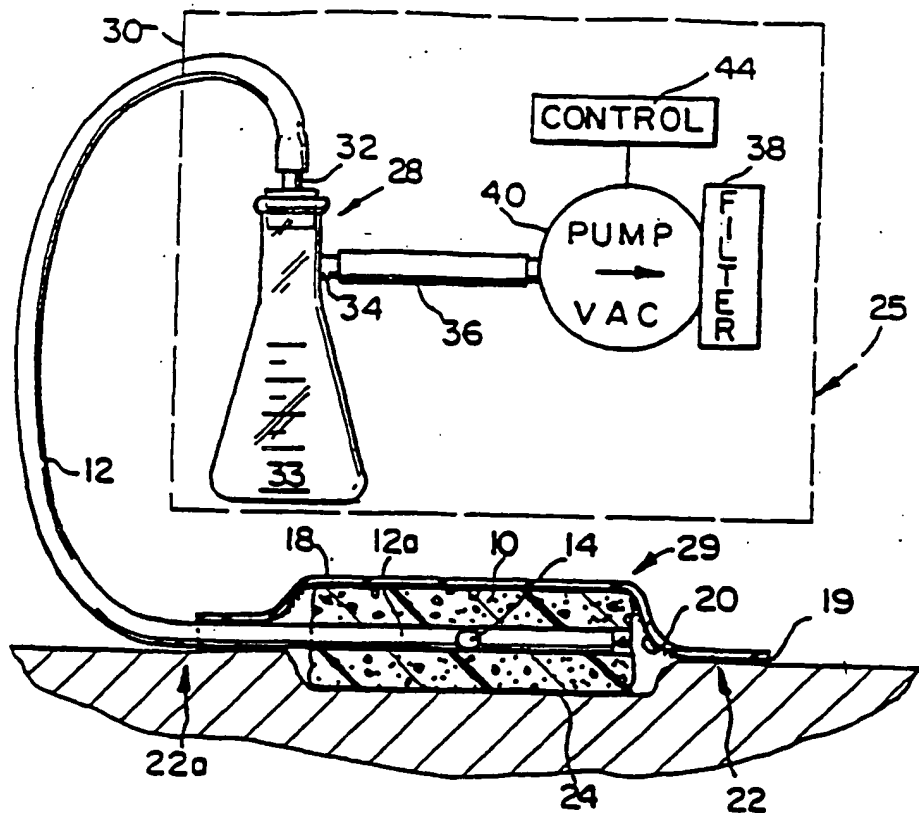

FIG. 1

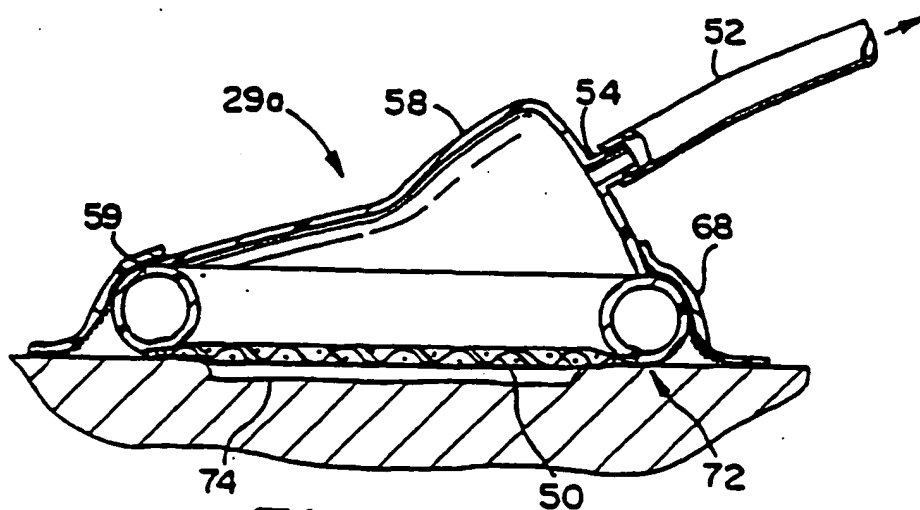

FIG. 2

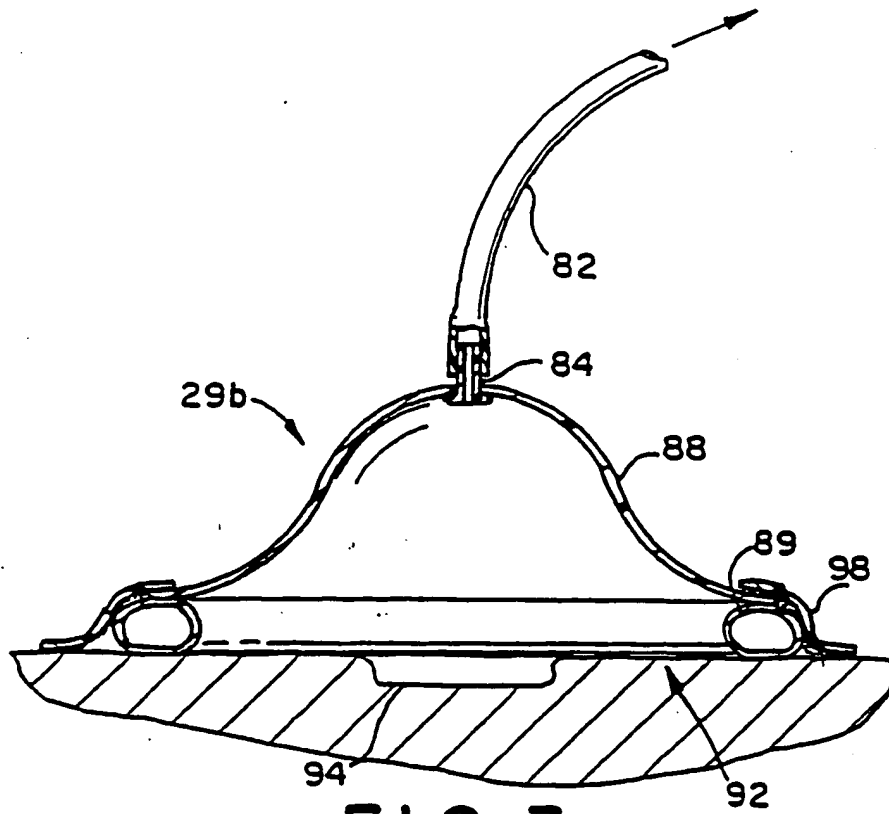

FIG. 3

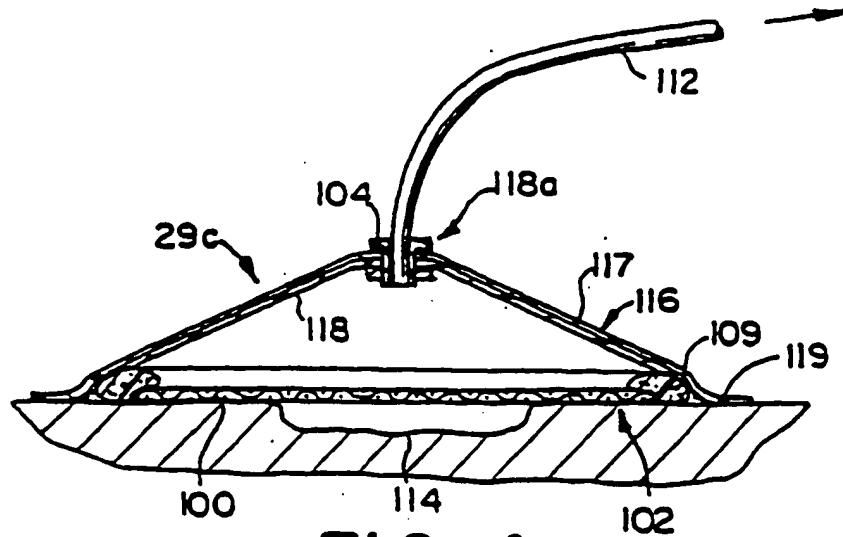

FIG. 4



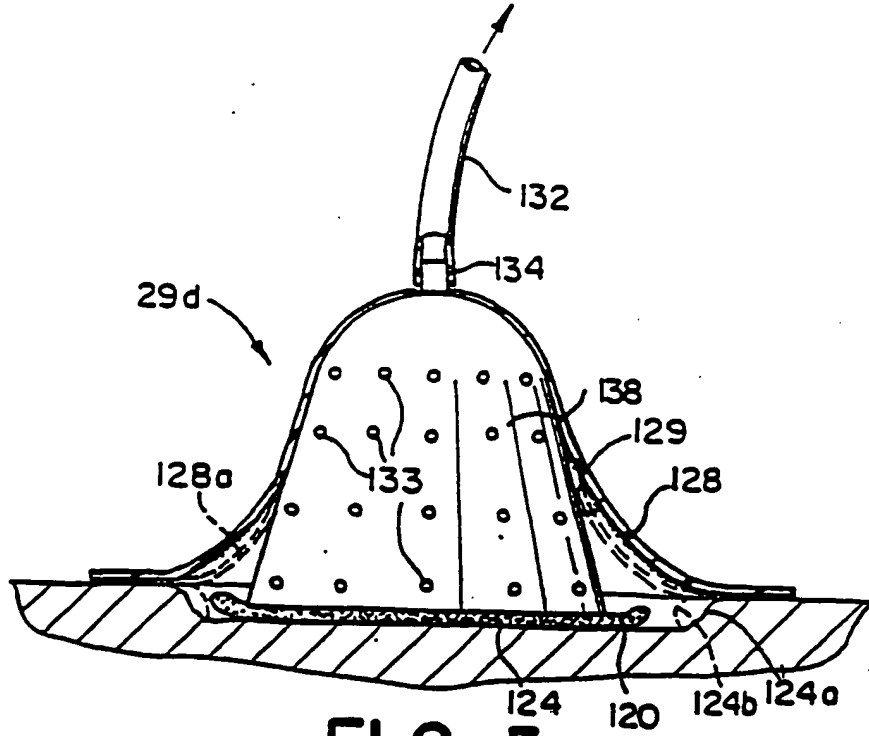

FIG. 5

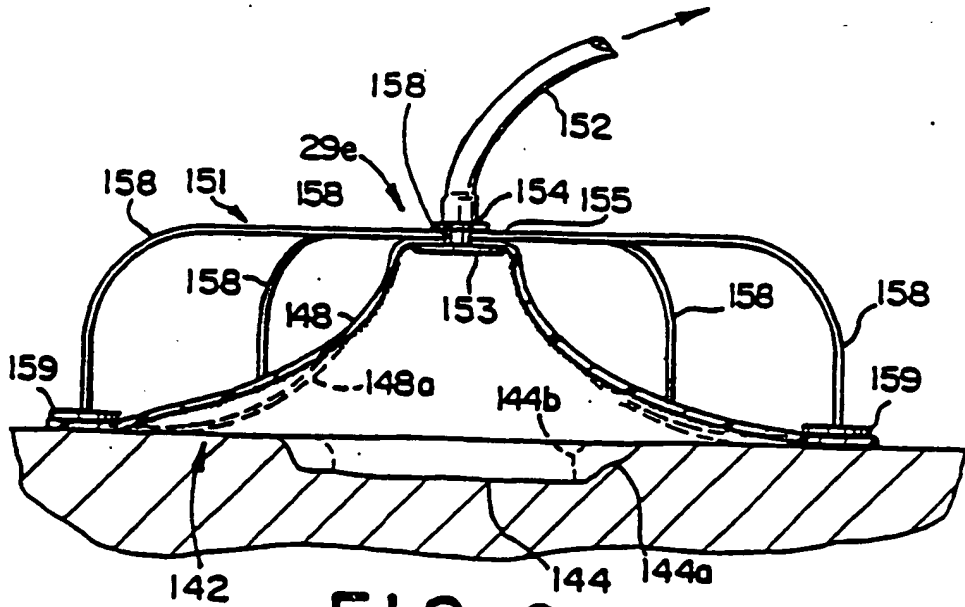

FIG. 6

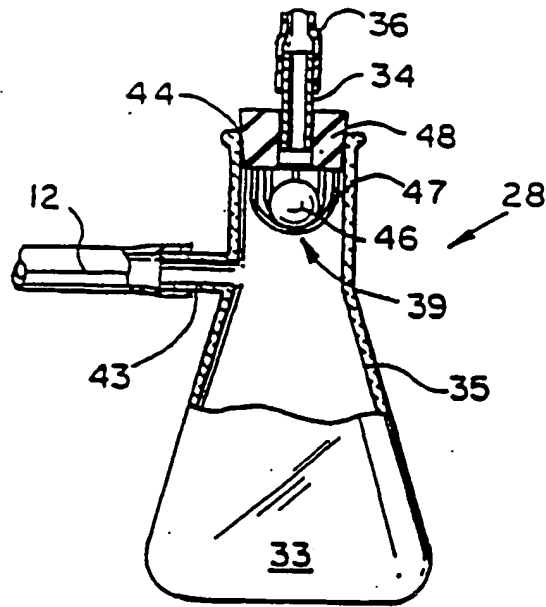

FIG. 7

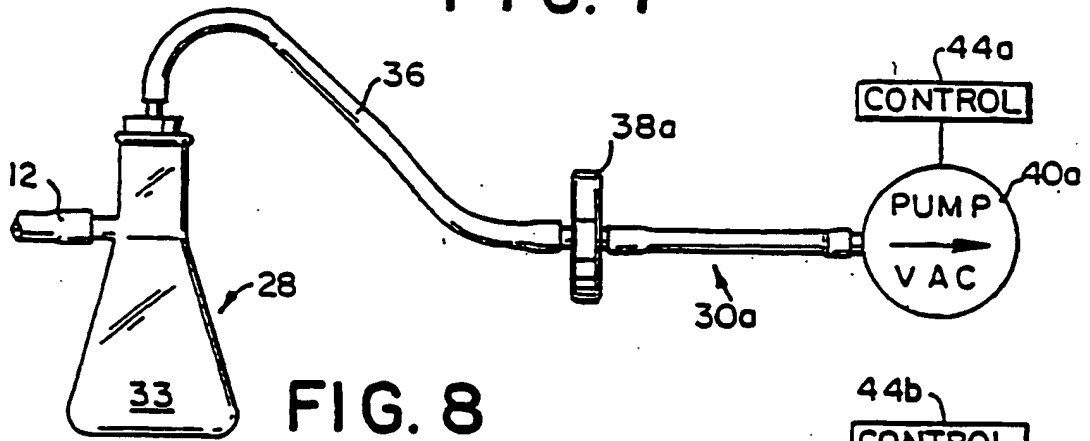

FIG. 8

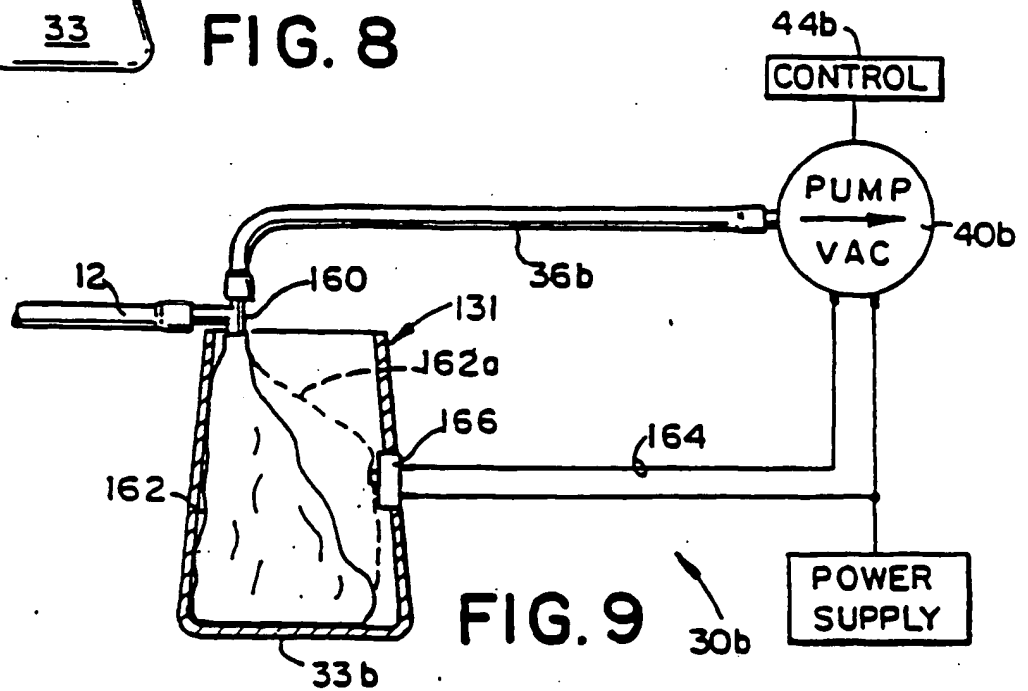

FIG. 9

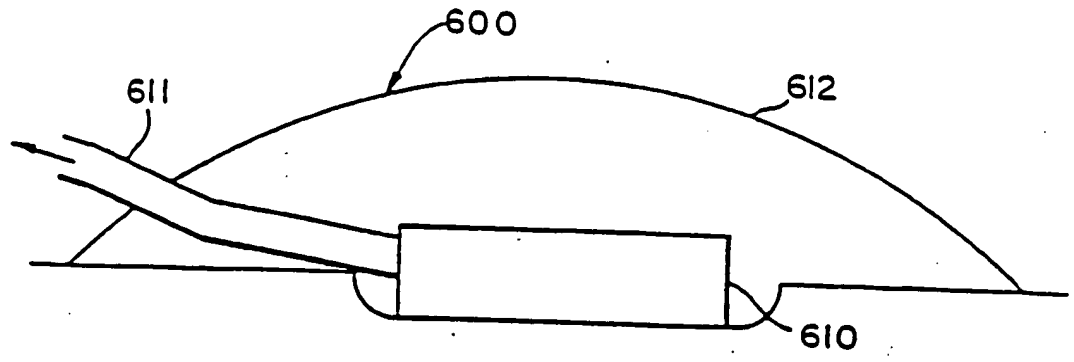

FIG. 10

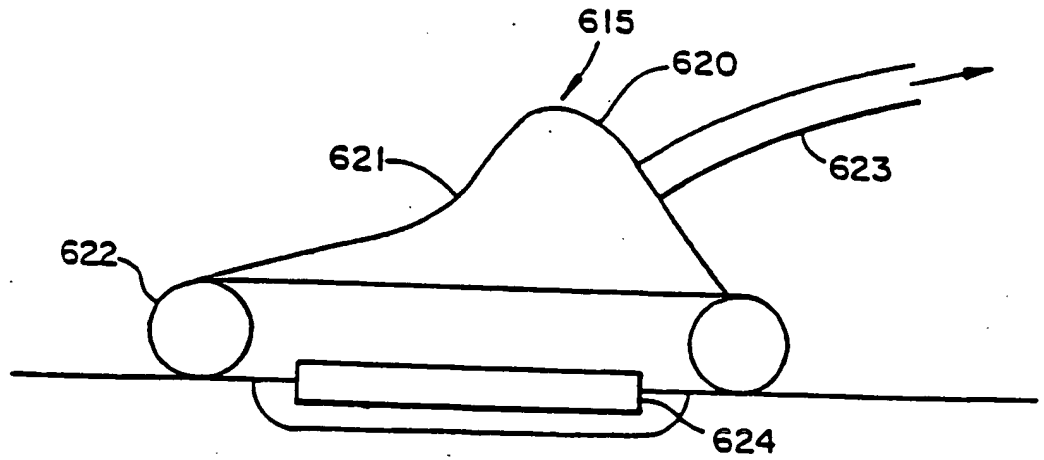

FIG. 11